

*Presented in Collaboration
with the **Tug Hill Commission***

Energy Storage in NYS: Market Drivers, Technologies, and Community Considerations



NYSERDA

Stillwater, NY

Energy Storage in NYS:

Market Drivers, Technologies,
and Community Considerations

Agenda

- Context: NYS's Electric Grid, Markets, Policies, and Programs
- Introduction to Energy Storage Technologies
- Planning & Zoning Considerations for Energy Storage
- Energy Storage & Fire Safety
- Resources for Local Governments
- Q&A

A photograph of a power substation. In the foreground, a worker wearing a bright yellow high-visibility safety vest, a blue hard hat, and grey pants is walking from left to right. Behind him is a large, white, rectangular electrical transformer mounted on a metal base. The transformer has several cooling fans on top. To the right of the transformer is a yellow safety railing. The ground is covered in gravel. In the background, there are other transformers, power lines, and a cloudy sky. The text "Context: NYS's Electric Grid, Markets, Policies, and Programs" is overlaid in the center of the image in a large, bold, blue font.

Context: NYS's Electric Grid, Markets, Policies, and Programs

Energy Storage in NYS:

- **Context**
- Energy Storage Technologies
- Planning & Zoning Considerations
- Energy Storage & Fire Safety
- Resources for Local Governments
- Q&A

Why are we talking about energy storage?

Critical questions driving grid infrastructure planning and investments:

- Do we have enough (+ *when we need it*)?
→ **'Resource Adequacy'**
- Can the grid withstand strain / challenges?
→ **'Reliability' / 'Resilience'**
- Can we avoid/minimize/manage costs of grid investments, operations, maintenance?
→ **'Affordability'**

Energy Storage in NYS:

- **Context**
- Energy Storage Technologies
- Planning & Zoning Considerations
- Energy Storage & Fire Safety
- Resources for Local Governments
- Q&A

Energy storage helps address those critical questions for various sectors/stakeholders:

- Residential customers
- Commercial customers
- Electric service utilities (e.g. National Grid)
- Grid operators (NYISO)

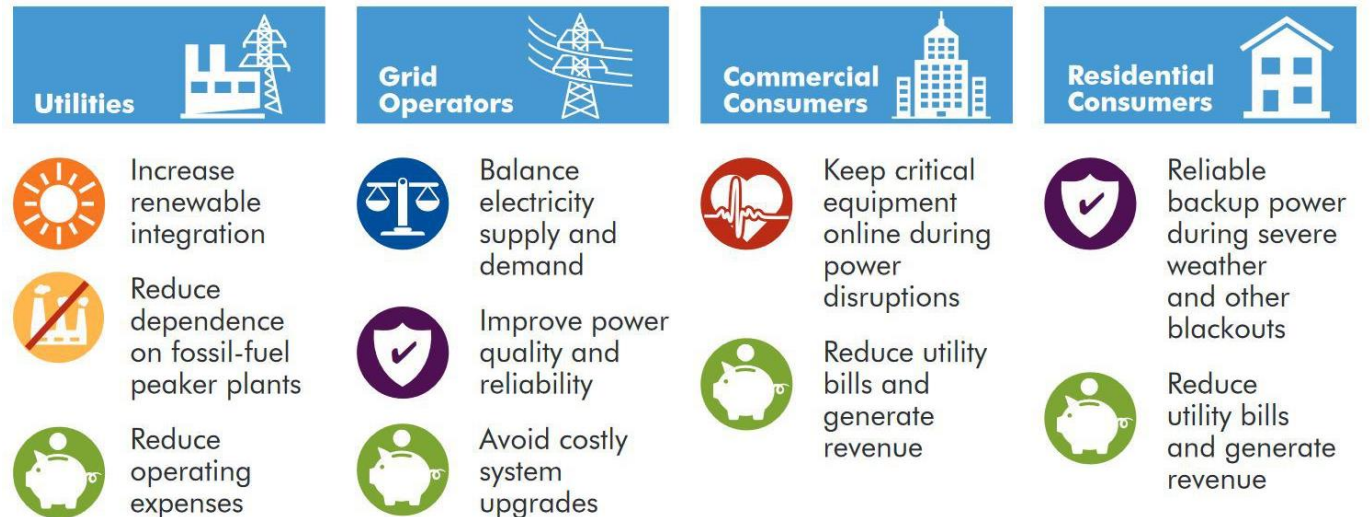

Energy storage technologies have the capacity to benefit each segment of the power system.

Context: NYS's Electric Grid, Markets, Policies, and Programs

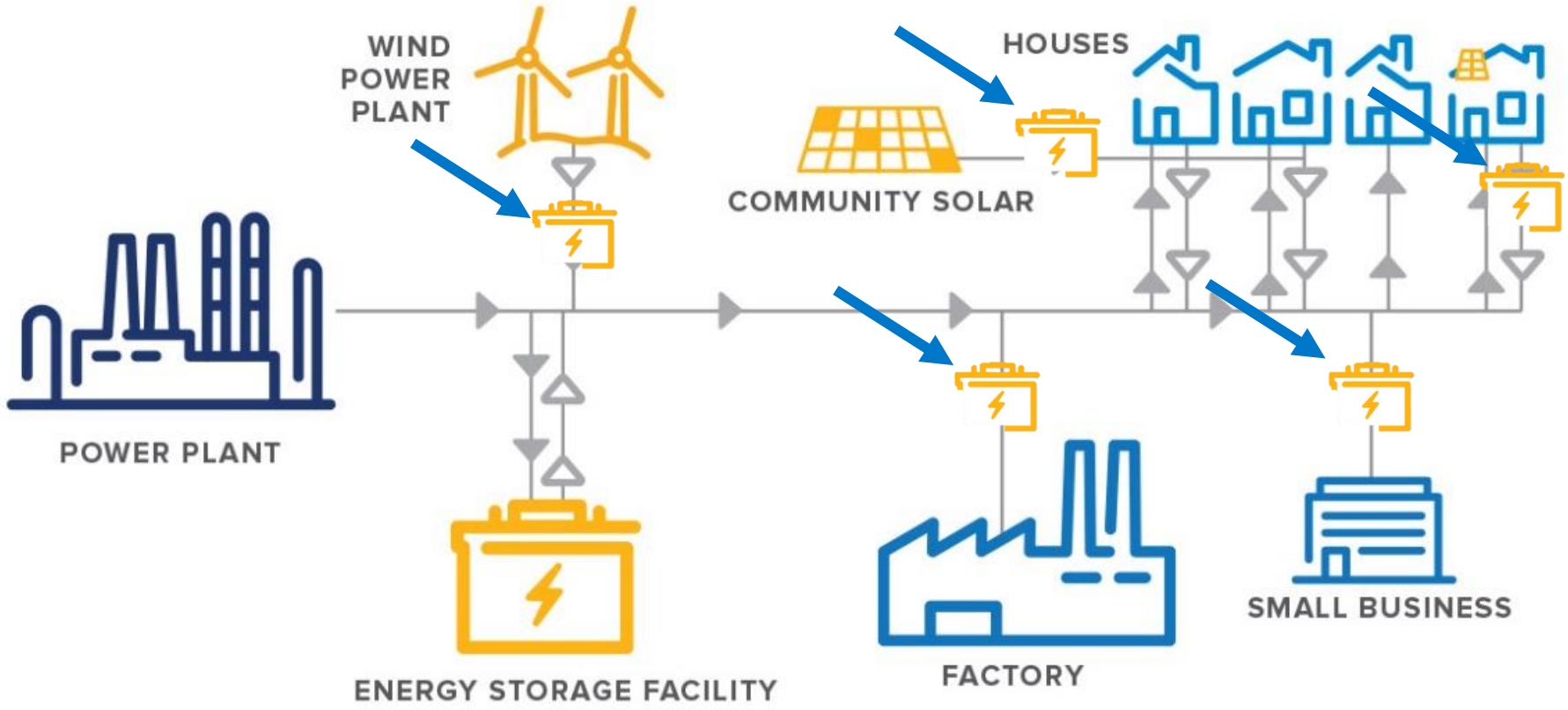

Energy Storage in NYS:

- **Context**
- Energy Storage Technologies
- Planning & Zoning Considerations
- Energy Storage & Fire Safety
- Resources for Local Governments
- Q&A

Why else are we talking about energy storage?

Grid Operations and Markets:

- New York Independent Systems Operator (NYISO) Wholesale Markets:
 - Energy markets (day-ahead, real-time)
 - Ancillary services markets (voltage support, regulation & frequency control, operating reserves)
 - Capacity market
- Electric utilities (e.g. National Grid, NYSEG):
 - Non-wires alternatives (NWA) investments

Energy Storage in NYS:

- **Context**
- Energy Storage Technologies
- Planning & Zoning Considerations
- Energy Storage & Fire Safety
- Resources for Local Governments
- Q&A

Why else are we talking about energy storage?

Load growth (Manufacturing, economic development projects, data centers, consumer and transportation electrification, etc.)

Large Load Interconnection Queue

29 PROPOSALS, 6,055 MW AS OF JULY 2025

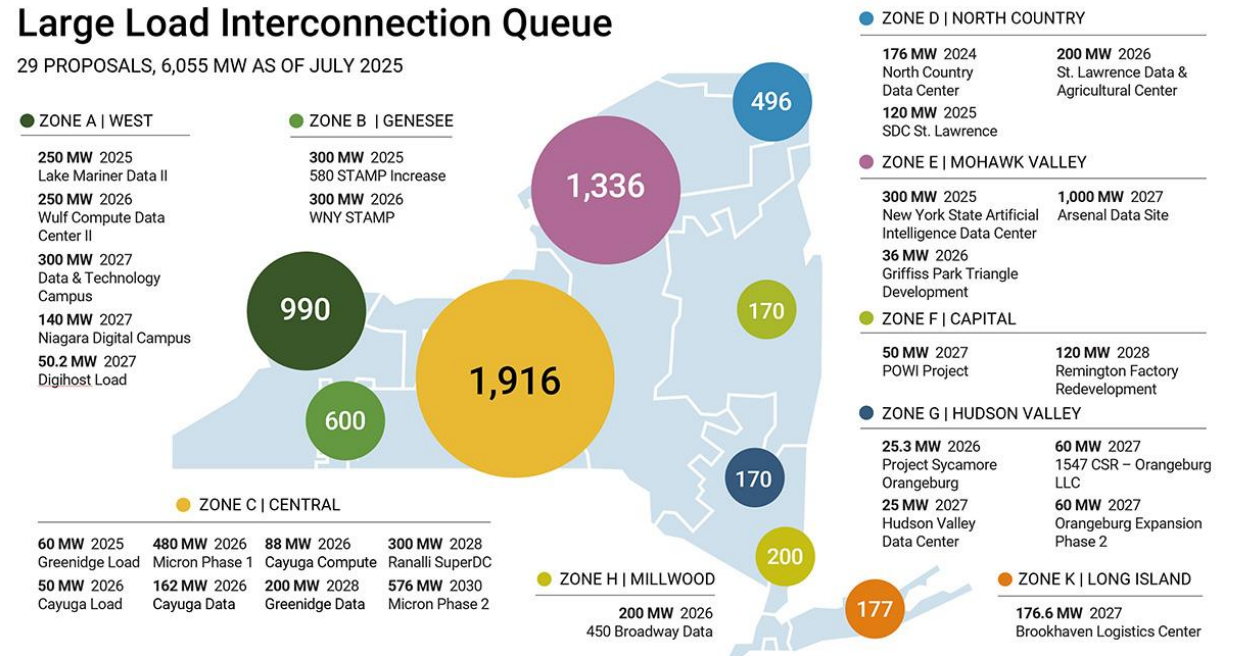

Energy Storage in NYS:

- **Context**
- Energy Storage Technologies
- Planning & Zoning Considerations
- Energy Storage & Fire Safety
- Resources for Local Governments
- Q&A

Quick Primer: Watt's in a watt?

Energy technologies are often described by system “capacity,” i.e. how much electricity they generate, store, or consume. What does that refer to?

Watt (W): a measurement of **power** (i.e. the rate at which something can generate or use electricity).

1 Kilowatt (kW) = 1,000 W

1 Megawatt (MW) = 1,000 kW

1 Gigawatt (GW) = 1,000 MW

Watt-hour (Wh): = a measurement of **energy** (i.e. the sum of electricity generated or used over a **duration** of time; energy = power x time)

1 Kilowatt-hour (kWh) = 1,000 Wh

1 Megawatt-hour (MWh) = 1,000 kWh

1 Gigawatt-hour (GWh) = 1,000 MWh

Analogy: Consider the container!



Context: NYS's Electric Grid, Markets, Policies, and Programs

Residential
"Behind the Meter"
~5-10 kW



On-Site Retail
"Behind the Meter"
~50-750 kW



Off-Site Retail
"Front of the Meter"
~1-5 MW



Bulk
"Front of the Meter"
>5 MW



Residential & Retail Program

Bulk Program

Energy Storage in NYS:

- **Context**
- Energy Storage Technologies
- Planning & Zoning Considerations
- Energy Storage & Fire Safety
- Resources for Local Governments
- Q&A

NYSERDA Bulk Energy Storage Procurement

To participate in ISCRFP25-1, projects must

- Be electrically interconnected to the NY grid
- Have at least 5 MW of power capacity
- Use commercialized energy storage technologies
- Be placed in-service by December 31, 2030

Projects are evaluated by a committee on the following factors:

- Price (60%)
- Non-Price (40%)
 - Project Viability and Maturity
 - Electricity System Value
 - Economic Benefits to NYS

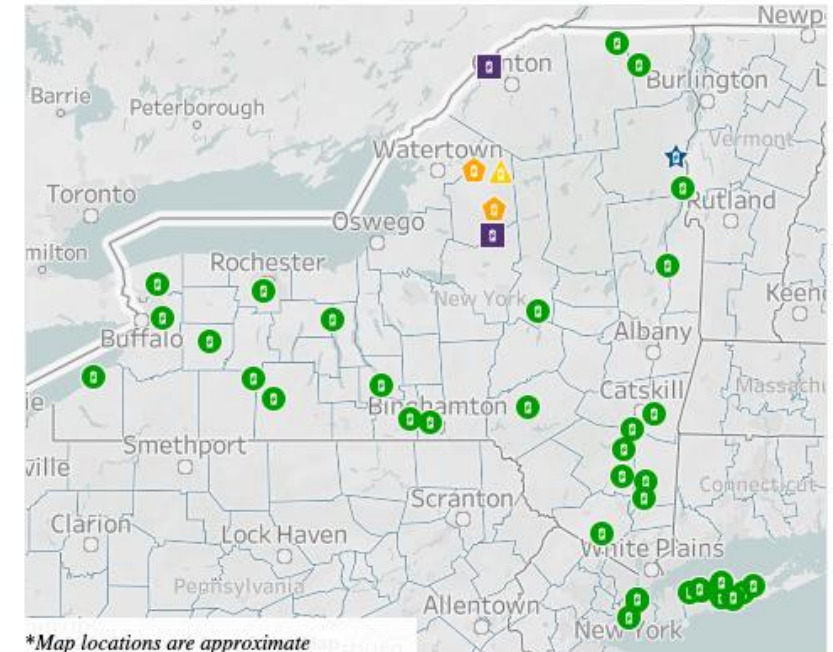

An aerial photograph showing a large-scale energy storage facility in Orangeville, NY. The facility includes several long, white, rectangular storage units, a central control building, and a complex of electrical infrastructure with numerous towers and power lines. The surrounding landscape is a mix of fields and dense forests, with a line of wind turbines visible in the distance under a clear blue sky.

Introduction to Energy Storage Technologies

Energy Storage in NYS:

- Context
- **Energy Storage Technologies**
- Planning & Zoning Considerations
- Energy Storage & Fire Safety
- Resources for Local Governments
- Q&A

- We want **electrical energy**
- Energy Storage = Technology which stores and/or converts one form of energy to another usable form (in this case, electrical energy)



- Examples of energy storage technologies:
 - Chemical
 - Mechanical
 - Thermal



Energy Storage in NYS:

- Context
- **Energy Storage Technologies**
- Planning & Zoning Considerations
- Energy Storage & Fire Safety
- Resources for Local Governments
- Q&A

NOT Hypothetical - Energy Storage Technologies Exist in NYS:



Energy Storage in NYS:

- Context
- **Energy Storage Technologies**
- Planning & Zoning Considerations
- Energy Storage & Fire Safety
- Resources for Local Governments
- Q&A

NOT Hypothetical - Energy Storage Technologies Exist in NYS:

Data beginning 2000
and current through:
December 31, 2025

Showing Data for:
New York State

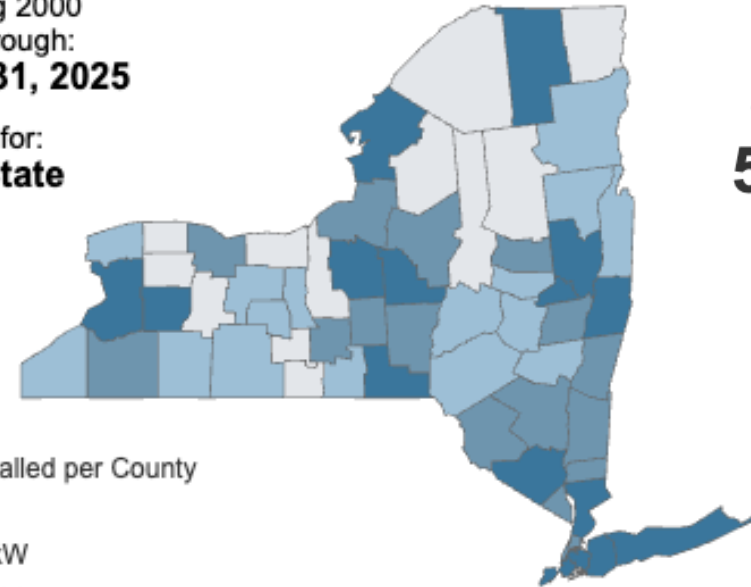

Total Capacity (MW AC)
528.66 MW

Number of Projects
7,494

Megawatts installed per County

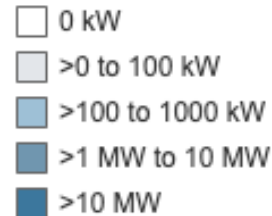

Energy Storage in NYS:

- Context
- **Energy Storage Technologies**
- Planning & Zoning Considerations
- Energy Storage & Fire Safety
- Resources for Local Governments
- Q&A

NOT Hypothetical - Energy Storage Technologies Exist in NYS:



Energy Storage in NYS:

- Context
- **Energy Storage Technologies**
- Planning & Zoning Considerations
- Energy Storage & Fire Safety
- Resources for Local Governments
- Q&A

Majority of energy storage being deployed today is battery energy storage, due to:

- Technology maturity
- System efficiency
- Falling costs
- Energy density
- Siting considerations
- Scalability

U.S. battery capacity increased 66% in 2024

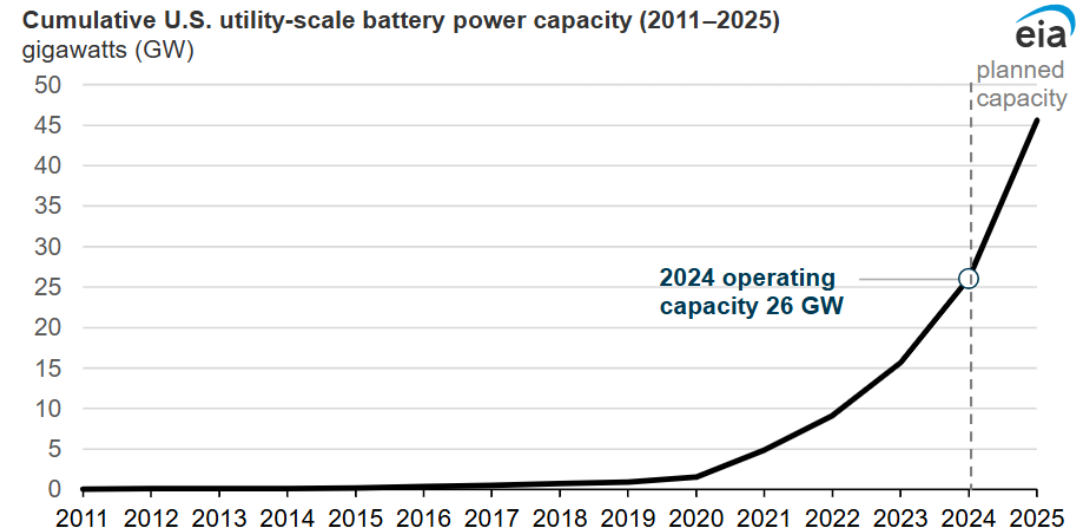

Data source: U.S. Energy Information Administration, Preliminary Monthly Electric Generator Inventory, January 2025

Energy Storage in NYS:

- Context
- **Energy Storage Technologies**
- Planning & Zoning Considerations
- Energy Storage & Fire Safety
- Resources for Local Governments
- Q&A

Battery Energy Storage Systems (BESS):

- Modular, scalable building blocks:



- Battery management system (BMS)
- Balance of system (BOS) equipment

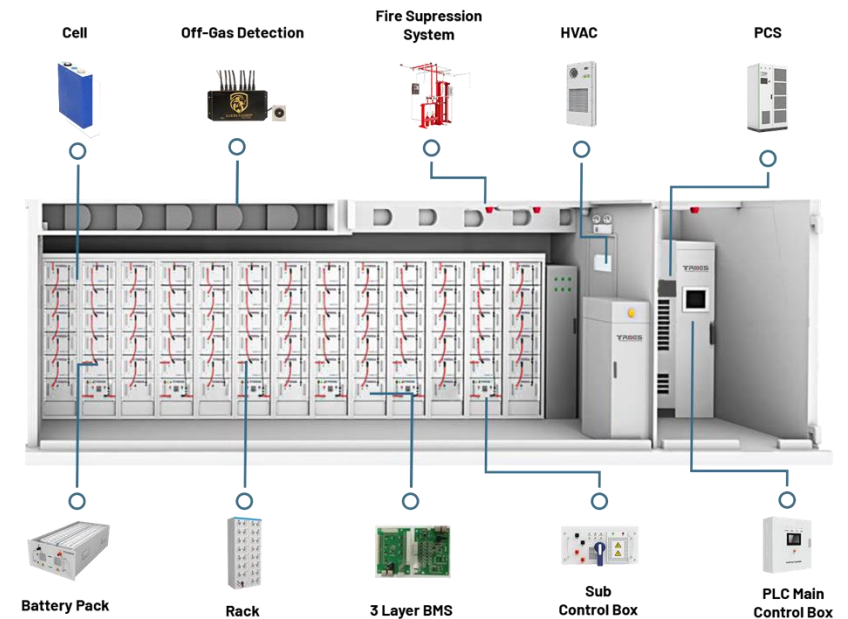

Energy Storage in NYS:

- Context
- **Energy Storage Technologies**
- Planning & Zoning Considerations
- Energy Storage & Fire Safety
- Resources for Local Governments
- Q&A

Battery Management System (BMS)

- Continuous monitoring down to the cell level
- Will alarm if there are potential issues
- If required, can isolate affected cells or modules from the total system and activate fire protection systems, preventing further failure
- Numerous safety features: cell balancing/monitoring, thermal management, charge/discharge protection, fault diagnosis/reporting



Energy Storage in NYS:

- Context
- **Energy Storage Technologies**
- Planning & Zoning Considerations
- Energy Storage & Fire Safety
- Resources for Local Governments
- Q&A

Battery chemistries:

Batteries are constantly evolving to address different variables:

- Safety
- Cost
- Energy density
- Physical footprint
- Charge/discharge factors

As a result, we have a diversity of market-ready chemistries:

- Alkaline
- Lead-Acid
- Nickel-based (NiCad, NiMH)
- Lithium-ion (LFP, NMC, etc.)



Introduction to BESS

So... why Li-ion?

	Lead Acid	Sodium-Sulfur	Flow Batteries	Lithium-Ion
Round-trip efficiency	70-85%	70-80%	60-80%	85-95%
Typical duration	2-6 hours	6-8 hours	4-12 hours	0.25-4 hours
Time to build	6-12 months	6-18 months	6-12 months	6-12 months
Operating cost	High	Moderate	Moderate	Low
Space required	Large	Moderate	Moderate	Small
Cycle life	500-2,000	3,000-5,000	5,000-8,000+	2,000-6,000+
Technology maturity	Mature	Commercial	Early-moderate	Commercial

Introduction to Energy Storage Drivers & Technologies

BESS continue to evolve to address numerous variables, including:

- Safety
- Costs
- Energy density
- Duration
- Physical footprint
- Material availability / recoverability

NYS as a leader in battery innovation:

New Energy New York (NENY) Coalition, led by Binghamton University, is one of 10 Regional Innovation Engines funded by the National Science Foundation.





Sandia National Laboratories

Introduction to non-Li Energy Storage Technologies



Ramesh Koripella, Ph.D.

Mar 31, 2026.



This material is based upon work supported by the U.S. Department of Energy, Office of Electricity (OE), Energy Storage Division.



Sandia National Laboratories is a multimission laboratory managed and operated by National Technology & Engineering Solutions of Sandia, LLC, a wholly owned subsidiary of Honeywell International Inc., for the U.S. Department of Energy's National Nuclear Security Administration under contract DE-NA0003525.

Few Technology Options for Long Duration Energy Storage.



Electrochemical (Batteries) Storage

- Lithium-Ion Batteries
- Sodium-Ion Batteries, Molten Sodium Batteries
- Zn-Based Batteries, Ni-H₂ batteries
- Metal-Air Batteries
- Flow Batteries
- Supercapacitors

Mechanical Storage

- PHS (Pumped Hydro Storage)
- Variations of PHS (Quidnet Energy, Sage Geosystems, RCAM)
- Gravity (ARES, Energy Vault)
- Compressed air (CAES), Compressed CO₂
- Flywheels (short duration storage)

Thermal Storage

- Molten salt thermal storage, ceramic particle storage media, Fixed bed thermal storage
- Heated brick (Antora, Rondo)
- Molten metal, liquid metal battery
- Liquid air energy storage

Chemical and Hydrogen Storage

- Electrolysis, H₂ storage, H₂ combustion, Fuel cells
- Hydrocarbon or ammonia conversion

Desired ES Characteristics:

- Ability to respond quickly for load demand
- High round trip efficiency
- Low self discharge
- High energy density
- Cost competitive
- Environment friendly
- Availability with good supply chain
- Safe

1. Electrochemical Cell (or Battery) – example: Li-ion cell

3



Electrochemical cell:

- Consists of two electrodes, anode and cathode in an electrolyte, separated by an ion conducting separator. Electrons flow through the outer circuit.
- During discharge electrons and ions flow from anode to cathode and during charge electrons and ions are forced to move from cathode to anode with the application of applied electric field.

Key Components:

- **Anode:** Graphite, Si, LiTiO_x
- **Cathode:** layered metal oxides, phosphates (LiNiCoAlO_2 , LiNiMnCoO_2 , LiFePO_4)
- **Separator:** polyethylene (PE) or polypropylene (PP) or a combination.
- **Electrolyte:** Li salt such as LiPF_6 dissolved in organic solvents (EC, DMC and DEC)
- **Current collectors:** Cu and Al

Key Characteristics:

- **Voltage** (V, volts) – determined by the reaction between the electrodes and the electrolyte
- **Current** (I, amps) – reaction rate (Amp = Coulombs/sec)
- **Power** (W, watts): $V \times I$
- **Capacity** (Ah or Wh): power as a function of time
- **RTE** (%): energy out during discharge/ energy in during charge
- **Self discharge:** typically expressed as % degradation/yr under open circuit conditions
- **Degradation:** cycle life (# charge/discharge cycles), calendar life (yrs)

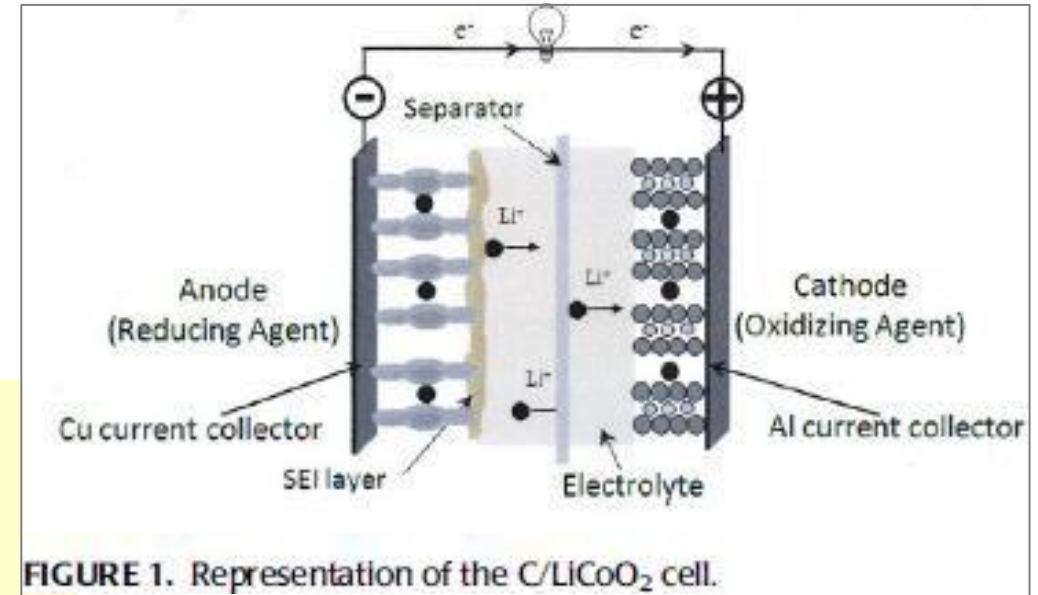
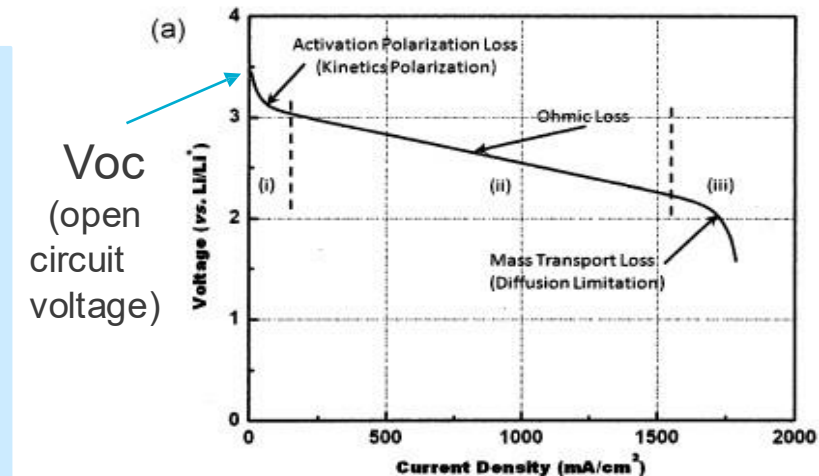

FIGURE 1. Representation of the C/LiCo₂ cell.



1. Electrochemical – Li and solid state batteries



Li-ion batteries

- The most dominant technology up to 4hr, as the costs are going down, they are becoming competitive at 8-10hrs also.
- They support a wide range of duty cycles with good RTE.
- Cost and safety are major concerns for LDES.
- **Different flavors of Li-ion batteries:** **LFP** (Lithium Iron Phosphate), **NMC** (Lithium Nickel Manganese Cobalt), **NCA** (Lithium Nickel Cobalt Aluminum Oxide), **LMO** (Lithium ion Manganese Oxide), **LCO** (Lithium ion Cobalt Oxide), **LTO** (Lithium Titanate Oxide)
- LFP is most preferred for grid scale applications. Slightly lower energy density compared to others, but less prone to thermal runaway and uses low cost raw materials.
- Oper. Temp. range: $-20\text{ }^{\circ}\text{C}$ to $60\text{ }^{\circ}\text{C}$, preferred range $20\text{-}25\text{ }^{\circ}\text{C}$

Solid State Batteries

- Uses thin film ceramic solid electrolyte separator replacing the liquid electrolyte and the polymer membrane.
- Promises higher energy density, better safety. Issues are degradation due to interfacial separation between the electrolyte and the electrode, fragility of the ceramic membranes. Thermal runaway issues are not fully mitigated. Still in R&D or early commercialization stage.

Li-ion technology choices

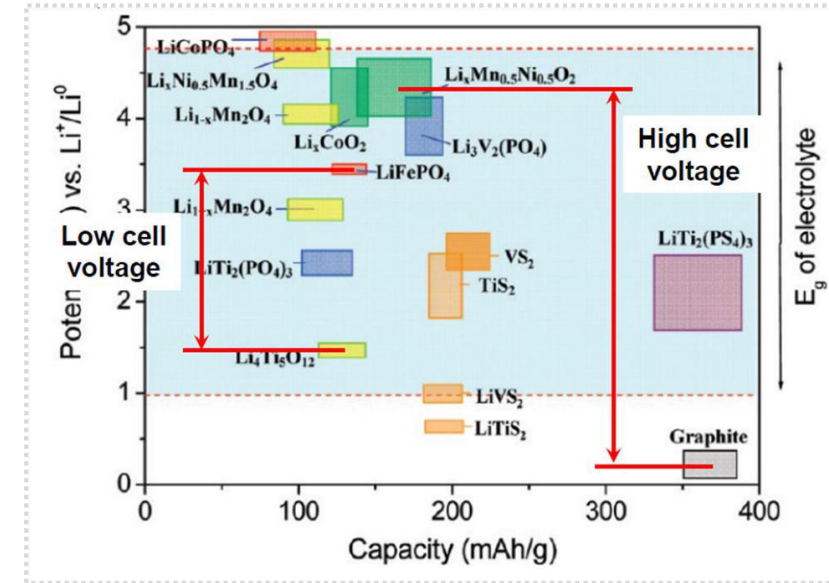

Tesla Megapacks, Moss Landing

Electrochemical – Na batteries



■ Sodium ion batteries

- There is a lot of excitement about Na-ion batteries. They use earth abundant materials that are lower in cost and safe (?). They are not yet in high-volume commercial manufacturing.
- **Different types of Na ion batteries:**
 - **High temperature** (molten Na-Sbatteries – NGK, BASF), Metal-Halide batteries (Na-metal chloride). **(GE closed its factory in Schenectady, NY ~ 10 yr ago)**
 - **Low temperature** (Li ion battery analogues). Several different types of chemistries are in development. Anodes: Hard carbon, Ti based intercalation oxides, conversion and alloying, Cathodes: layered oxides, polyanionic, Prussian blue. **Companies:** Faradion (**acquired** by Reliance), Natron (**bankrupt**), HiNa, CATL, Farasis, Tiamet, NorthVolt (**bankrupt acquired** by Lyten).
 - Less thermal runaway problems. They can be **shipped in zero charge state** (much safer during shipping).

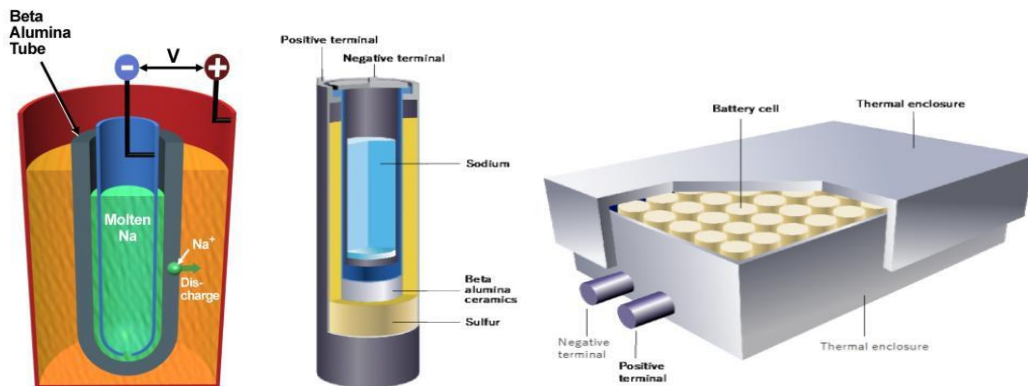

Commercial viability still an issue for this type of Na batteries due to cost and safety.

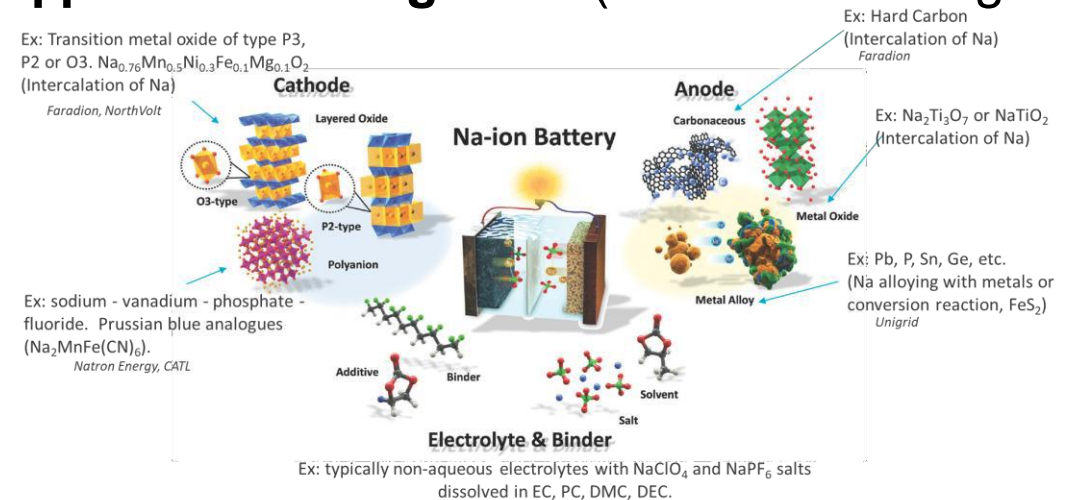

Low temperature Na-ion technology is more promising.

Na-ion batteries



- Chinese companies HiNa, CATL, BYD introduced several commercial products. Several US companies are also starting to commercialize this technology (Peak Energy, UniGrid, Alsym, few other companies).
- **Peak Power:** Sourcing Na ion cells from China, but assembling the battery systems in the US. Peak energy is saying they could compete at system scale with LFP because of the reduction in AC and cooling costs, and an overall lower balance of plant costs compared to LFP. Simpler system with just natural air cooling. Peak Energy claims that their polyanion cathode chemistry is better. Cap Ex may be slightly higher right now, but operations are less expensive (Op Ex). They are doing a major installation project in CO.
- **Unigrid** (out of UCSD) also has a variation of low temperature sodium ion battery, making good progress in scaling up manufacturing. They are using contract manufacturing for high volume.
- **Alsym:** another US based company (Massachusetts). Na series NFPP+ (sodium iron pyrophosphate) cells: 135 Wh/Kg, 250 Wh/L. Cycle life >10,000.

Na ion batteries:

- Offers better low temperature performance compared to Li ion batteries.
- They can be charged and discharged faster than Li ion batteries.
- Na ion batteries can be stored and transported in zero voltage. Safe for transportation. Li ion batteries should be stored at some minimum charge.
- Lower thermal runaway risk and safety concerns compared to Li ion batteries.
- Main challenges are: increasing the cycle life, increasing the energy density and scaling up for high volume manufacturing. Good progress is being made in these areas.

(Stanley Whittingham (Binghamton University), Nobel Laureate for Li ion battery invention, doesn't share the same enthusiasm with Na ion batteries)

Electrochemical – Flow batteries



- Flow Batteries:** Reactants are dissolved in a dilute electrolyte solution and circulated over anode and cathode. It allows the separation of power (battery stack) and energy (storage tank). Easy to scale up for larger system.
- Drawbacks:** Uses dilute solutions, so energy density is low. System complexity is high, requires more ancillaries such as pumps, sensors and control circuits. Needs bipolar stacks, uniform flow fields, ion conducting separator. Some flow batteries requires catalyst. Cross-over of species and higher self discharge. RTE ~65-75% Not competitive with Li-ion batteries for short duration storage.
- Different types of flow batteries:** few examples, V redox flow battery (**Invinity**), Fe flow battery (**ESS**), Zn-Br flow battery (**RedFlow -bankrupt**), Zn-Br hybrid battery (**EOS**). **CMBlu** –organic flow battery, uses a solid mediator to increase the energy density.

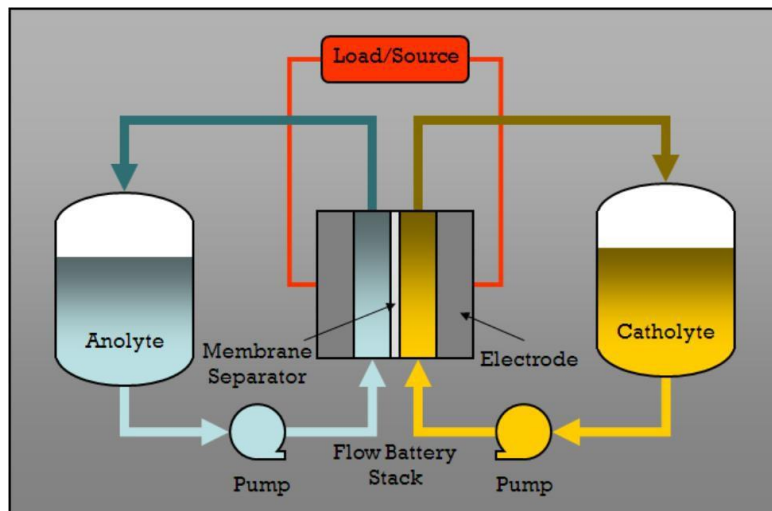

Invinity, V redox flow battery

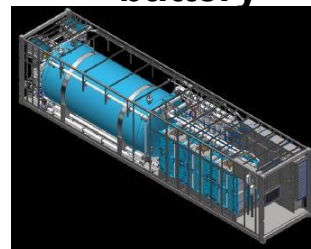

ESS, Iron Flow Battery



CMBlu organic flow battery



EOS, Zn-Br Hybrid battery



Red Flow, Zn-Br flow

Zn batteries for Energy Storage

There are different types that are being developed. Few examples are given below:

- **Zn-Ni** (ex: **Zinc Five**, good for pulse power applications – targeting AI data centers)
- **Zn-Mn** rechargeable Zn-Mn alkaline batteries (**UEP**, start up out of [City College of New York](#)) – early stages of commercialization.
- **Zn-air** (ex: **e-Zinc**) – early stages of commercialization.
- **Zn-Halide** (mostly Zn-Bromine) – flow and non-flow types. **RedFlow** ([bankrupt](#)), **Eos**.

Main advantages are low cost, stable supply chain and safety compared to Li-ion batteries.

Zn Halide or Zn-Br batteries

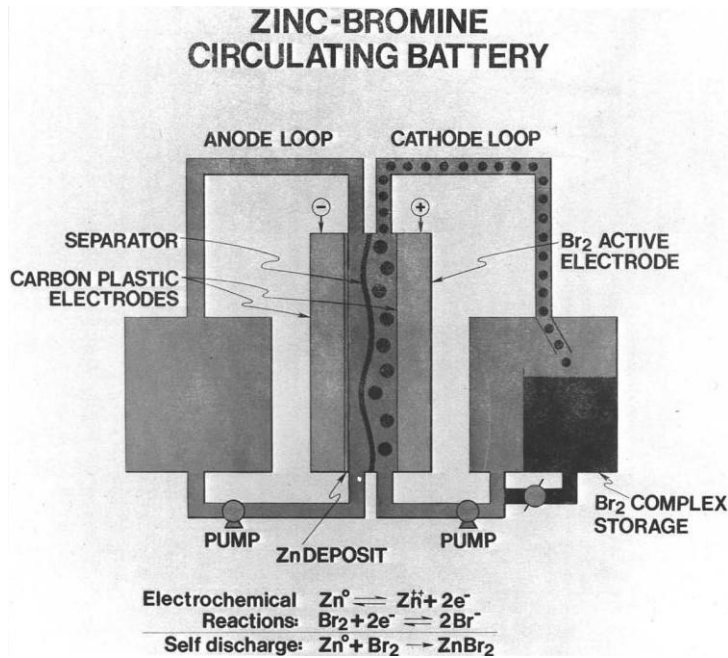

Zn-Br electrolyte solution circulating separately in two loops (anode and cathode side).

During charging:

Zn deposits on anode and Br gas generates at cathode. Br is complexed in the solution and segregated.

During discharge:

Zn dissolves into electrolyte, complexed Br goes back into electrolyte.

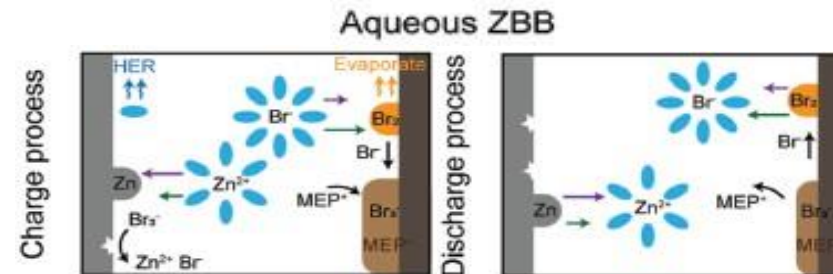

These are also known as hybrid batteries because it involves plating and stripping.

Electrolyte ($ZnBr_2$ solution with a Br complexing agent and few other additives). During operation, approximately 70% of the $ZnBr_2$ is converted to Zn^0 and Br_2 at full charge.

Electrodes: Br is very corrosive to most metals, Cor C/polymer composite or Ti/C are used as electrodes. Cathode is made more porous to increase surface area for Br reaction.

During charging the V is kept below 2.1V/cell. At higher V, electrolysis of water and H_2 generation concerns. Typically charging is done at a relatively low current density of 15-30 mA/cm² and over a long time.

Eos - Zinc hybrid Battery – Zynth battery module

- This is also a Zn-Br battery but with **no active pumping of electrolyte**. It is an **innovative passive design**.
- Their proprietary technology involves the battery architecture, electrolyte composition, additives, bipolar plates, battery management and manufacturing process.
- Uses a near neutral aqueous electrolyte solution, with proprietary additives and buffering agent.
- **Basic building block of Eos product is Znyth (zinc hybrid cathode) battery module.**
- **It is a static, sealed Zn-Br hybrid battery.**
- Eos is currently moving to their Gen 3.0 design from their earlier Gen2.3 battery modules.



Plastic enclosure,
It consists of several carrier
plates welded together

Electrolyte fill holes. Sealed
after filling.

One of the end plate
with both + and -ve
connections

Zynth 2.3 Battery module

- Each Znyth 2.3 battery module consists of 20 cells in series.
- Rated power of 0.8 kW.
- The battery size: 15.2”x16.9”x23” (~6000 in³ or 96.8 L),
- Weight: 215 lbs (or 98 Kg).
- Energy density is low, but a simpler system.
- Safe and potentially lower cost.



Gen 2.3 and Gen 3 Designs

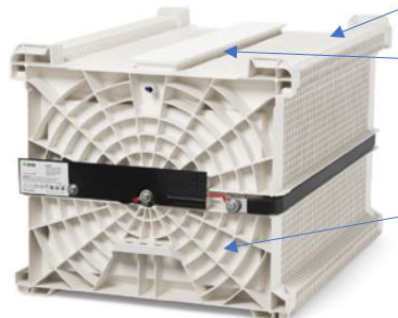

Plastic enclosure, It consists of several carrier plates welded together

Electrolyte fill holes. Sealed after filling.

One of the end plate with both + and -ve connections

Znyth 2.3 Battery module

20cells in series
 Rated power: 0.8kW
 Vol: 15.2H x 16.9W x 23.0D in = ~ 97L
 Weight: 215 lbs / 98 kg

Next generation Battery. **Higher energy density , lower cost**

Eos Znyth: 3



1 Non-degradable bipolar electrodes
 2 High-performance aqueous electrolyte
 3 Fully-sealed polymer casing

Znyth 3.0 Battery module

40cells in series
 Rated power: 2 kW
 Vol: 7.3H x 14.7W x 12.4D in = ~ 22L
 Weight: 45 lbs / 20.5 kg
 Projected Energy Density: 110Wh/L

Eos - Zinc hybrid Battery – Energy Cube



- Energy Cube combines 144 of Znyth battery modules into a 10'x20' size container.
- Each cube: 125 kW/500 kWh.
- 12 battery modules in series for battery strings, 6 strings connected in parallel on each side of the container.
- Operating temperature range: -20C to 50C.

Energy Cube

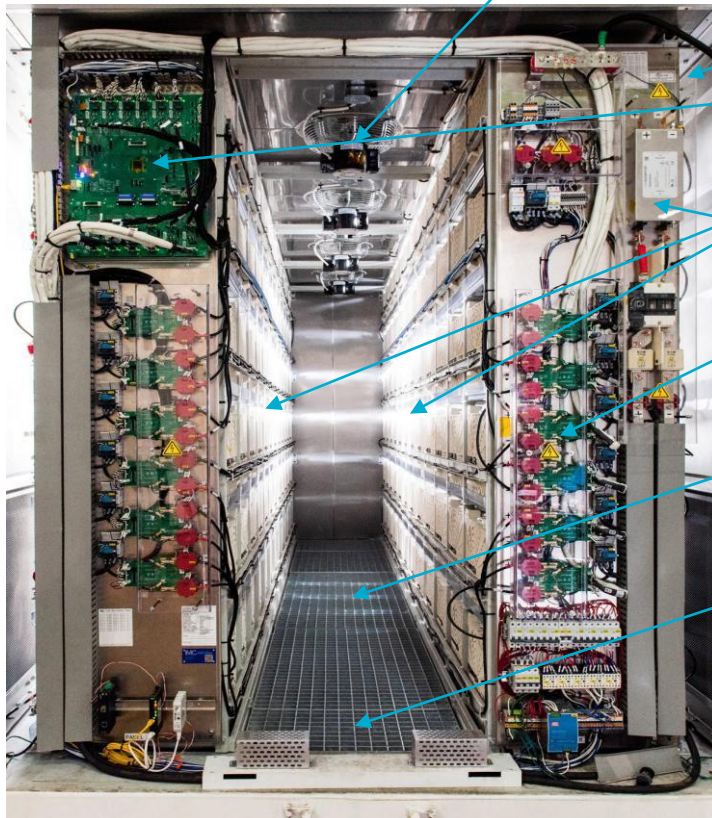

- Air circulating fans
- 10'x20' container
- Energy management system (EMS)
- Znyth battery modules
- Inverter
(for converting DC power to AC)
- Battery Strings monitoring
- Gap for recirculating air
(for dissipating heat from bat. Operation)
- Heaters at the bottom
(for very cold temperature operation)

Eos Znyth™ 2.3



Energy Cube

Safe, but certain operating limitations exist.



Mechanical Energy Storage

Mechanical Storage (can meet short, medium and long-duration storage needs)

- **Pumped Hydro Storage (PHS)** – commercial, currently the largest storage
 - Variations of PHS (Sage Geothermal, Quidnet Energy, Sperra (formerly RCAM)) – R&D or early commercialization stage
- **Gravity** based energy storage
 - Concrete blocks on cranes (Energy Vault), on Railcars (ARES) –R&D or early commercialization stage
- **Compressed air** energy storage (CAES)
 - early commercialization stage
 - Adiabatic compressed air (A-CAES)- Hydrostore,
 - Diabatic compressed air (D-CAES)
 - Variations – liquefied air, compressed CO₂ - CO₂ Dome
- **Flywheels** (commercial - suitable for short duration storage)

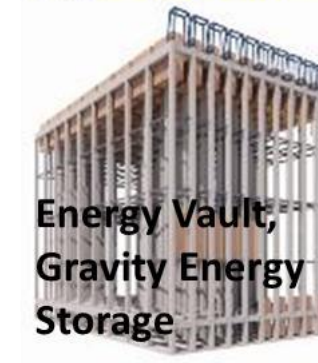
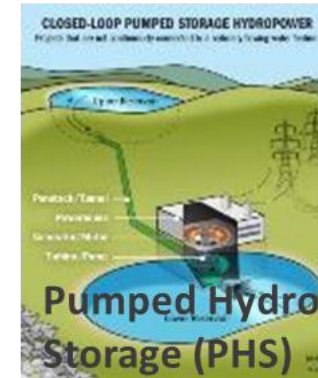

Pumped Hydro Storage (PHS)

- **Mature technology.** Good for 4-24 hr duration. RTE: 75-85%.
- Power capacities range from 100's of MW to several GW
- It can serve a wide range of grid storage applications
- Currently > 90% of US energy storage is PHS.
- Long lifetime: 50-60 years
- Capital investment is high; storage cost is low. Operation and maintenance costs are also low.

Disadvantages:

- Geographic constraints.
- Long permitting process.
- Higher capital investment.
- Very few new investments. But older systems are getting refurbished to increase operating life.

Few new proposed projects:

- Goldendale Energy storage project (1.2 GW) in Washington state. Received 40 yr license. Redeveloping Brownfields facility –former aluminum smelter facility. Rye development
- Lewis Ridge PHS in Kentucky (Coalfields-to-energy), 266 MW project, Rye
- Swan Lake Energy Storage Project (400 MW) in Oregon, Rye.
- Western Navajo 1 PHS project (500 MW) in Arizona, Rye.
- Carrizo Four Corners PHS project in NM (NM state and Navajo Nation collaboration), 1.5 GW, 70 hr duration.

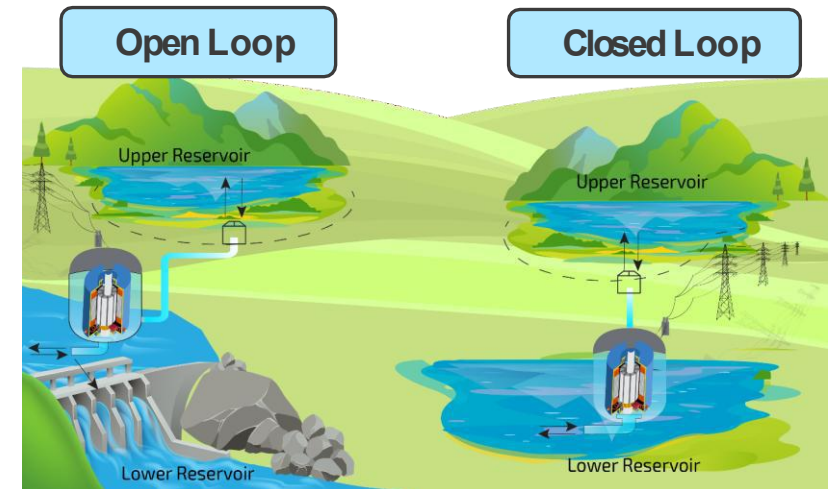

Compressed Air Energy Storage (CAES)

Compressed air (CAES)

- Use electricity to compress air, store it and then re-expand to generate electricity. Compression of air generates heat.
- Two types of CAES: diabatic, adiabatic. In adiabatic the heat of compression is captured for higher efficiency. In diabatic the heat is not captured. Typical RTE: 55-65%.
- Compressed air can be stored above or under ground.
- A-CAES system consists of an air compressor, a storage chamber that holds pressurized air, a thermal energy storage facility and turbine.
- Two old CAES systems in operation, recent proposals are in development stage.
- CAES cannot respond fast, and they are not suitable for power quality voltage and frequency regulation applications.

Variations of CAES: Liquid air energy storage (LAES), CO₂ dome, Storing compressed air or gas in gas pipelines, a combination of compressed air and water head.

Energysdome - Compressed CO₂

- Working fluid is CO₂.
- Easier to deal with than air. Clean CO₂ is used. CO₂ has higher molar mass than air, so smaller turbo machinery is needed. Critical temperature is 31C.
- Proof of concept demonstration project done in Italy.
- Uses existing technology. Sacrifices some efficiency for system simplification and reliability.
- Limiting the phase change and not capturing all the heat in the thermodynamic cycle

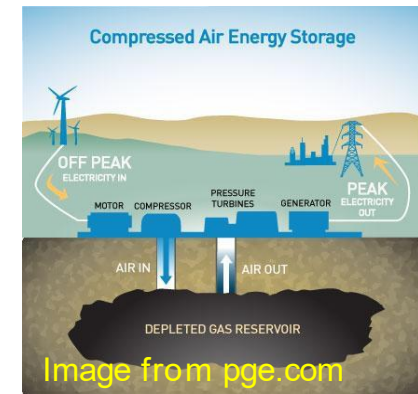

<https://newatlas.com/energy/hydrostor-compressed-air-energy-storage/>



Energysdome, <https://energysdome.com/>

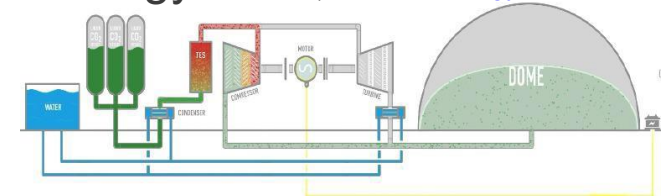

Energy Dome – Compressed CO₂ storage

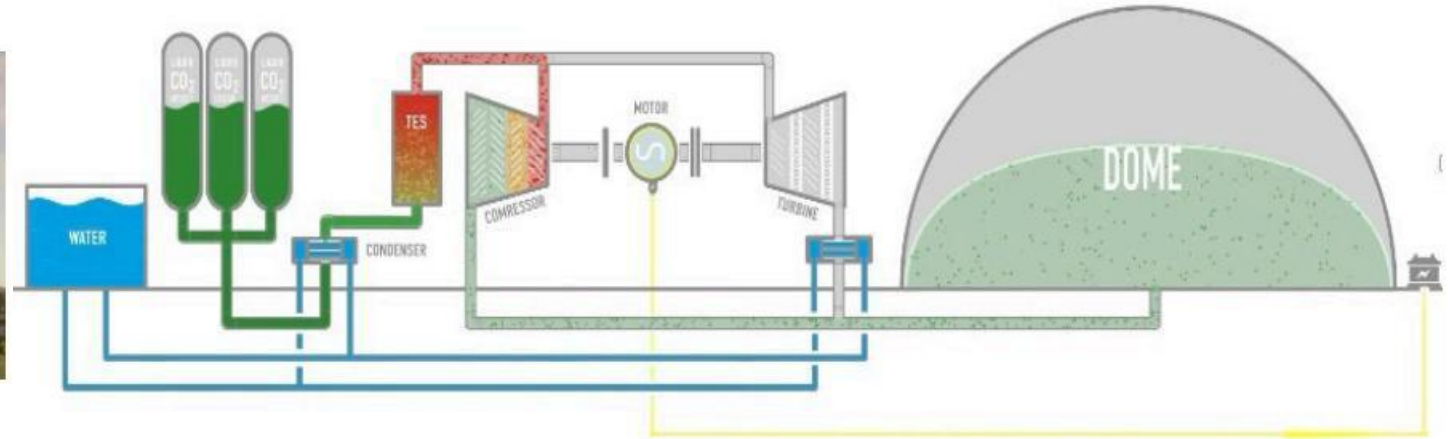
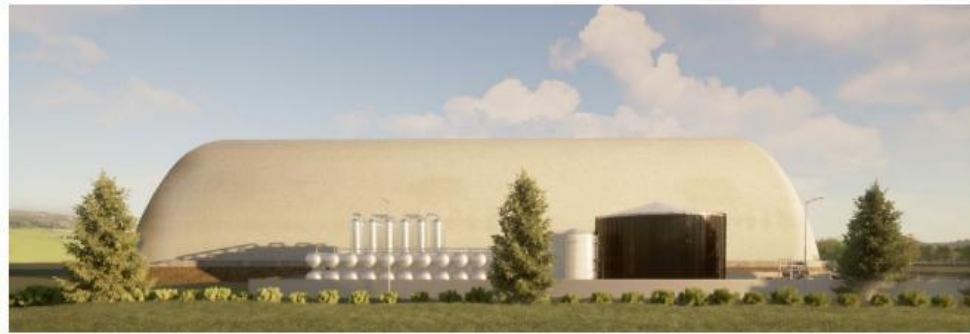

- 20 MW x 10h Commercial Module - Needs 10 to 12 acres of land (mostly for dome) - Dome height is 45 m (@ 150 ft). Outside rigid dome, inside bladder moves up and down with gas.
- Used all commercially available equipment for a quick demo.
- Working fluid CO₂. It can be stored as a liquid at ambient temp in carbon-steel pressure vessel, no cryogenics or chillers needed, Cleaner fluid, less contaminants, higher molar mass relative to air, so smaller turbo machinery. Not corrosive.
- Not going to supercritical CO₂ and eliminated the cold storage for simplicity.
- Development started on CO₂B Version 3.0, unit with larger turbine/compressor and higher efficiency (Pilot plant V1.0, Commercial Plant V2.0).
- Capex: \$225-250/kWh, RT 75%, 30+ yr lifetime

Proof of concept demonstrated. Low energy density. Need to understand the scale up issues, operating costs, self discharge losses and RTE.

3 main states

- 1 Charging**
 - CO₂ withdrawn from atmospheric gasholder (Dome), and compressed by inter-refrigerated compressor
 - Heat generated from compression stored into Thermal Energy Storage System (TES)
 - CO₂ is condensed into liquid state
- 2 Idle**
 - Liquid CO₂ stored at ambient temperature in CO₂ vessels
- 3 Discharging**
 - Liquid CO₂ is evaporated and heated by recovering heat from TES
 - Reheated CO₂ expands in turbine, returning power to the grid
 - Gaseous CO₂ is stored in Dome at ambient temperature and pressure without emissions to atmosphere

Hydrostor – Advanced Compressed Air Storage

- Compress air using electricity
- Capture the heat of compression in above ground thermal storage
- Store compressed air in hard rock caverns
- Convert compressed air to electricity.
- Proposing a 4GWh project in CA. Got approval to start the project but not started yet.
- **Very similar to CO₂ dome, this uses air instead of CO₂, and storing the gas in under ground versus in a balloon like tent.**



Proposed project in Kern County, CA

Still in the very early stages of demonstration

Variations of PHS for energy storage



Quidnet Energy - Geomechanical Pumped Storage – Subsurface Pumped Hydro

How it Works

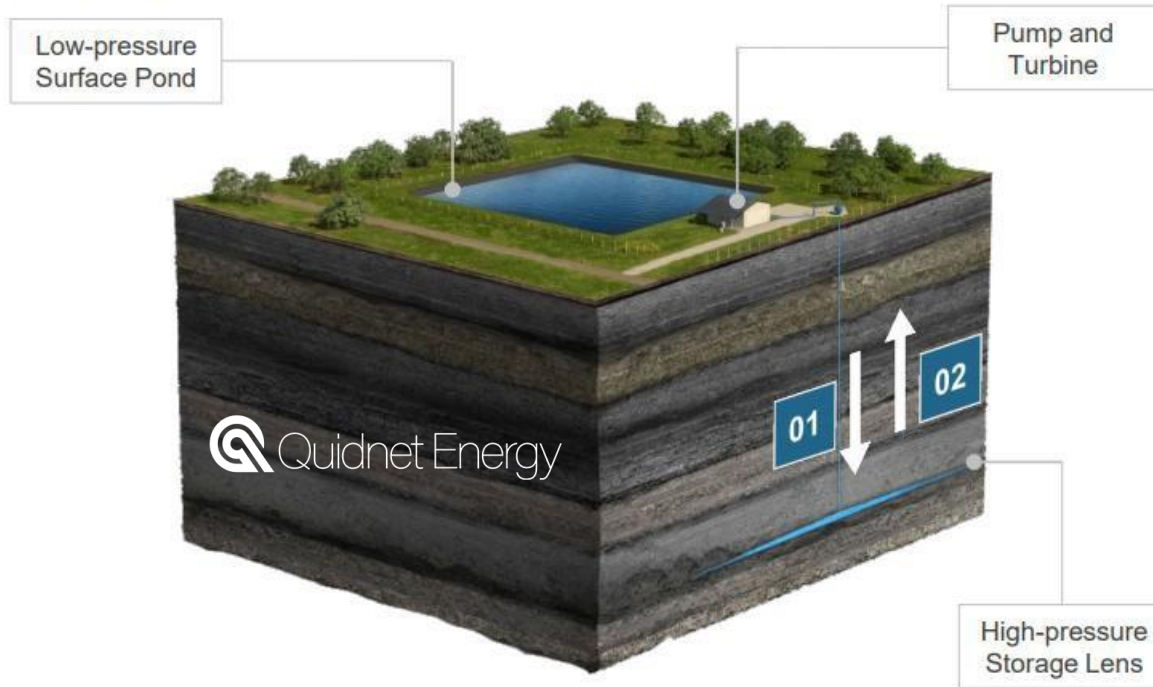

01 Charge. Water pumped down the well into high-pressure storage lens

02 Discharge. High-pressure water flows up the well to drive a turbine

Storage Process

- Pump water from a pond down a well into a body of rock.
- The well is closed, keeping the energy stored under pressure between rock layers for as long as needed.
- When electricity is needed, the well is opened to let the pressurized water pass through a turbine to generate electricity, and return to the pond ready for the next cycle.

1-10 MW systems,
10+ hour modules

Proof of concept stage

Sage Geosystems – pressure geothermal system



Sage Geosystems CEO Cindy Taff, shown second from right, stands with her team at the Texas test site. (Sage Geosystems)



Water drives a pair of turbines at the Starr County test site. (Sage Geosystems)

- Pump water into underground geological fracture between rocks (similar to fracking for oil wells).
- Store water under pressure – **charge**
- For **discharge** – release water – run a Pelton turbine and generator.
- They don't discharge completely or charge fully to keep the rock fissures flexing elastically. It is like breathing.
- Ability to control the discharge rate. Efficiency 70-75%
- Demonstration project done in TX with San Miguel Electric Cooperative.
- Patterned with Ormat, a traditional geothermal energy company.
- **Promising technology and company to watch**

Underwater Pumped Hydro (Sperra - formerly RCAM Technologies)



Subsea storage solution integrates with offshore energy generation to provide firm, steady power

Spheres buried 100-2000 m deep on sea bed

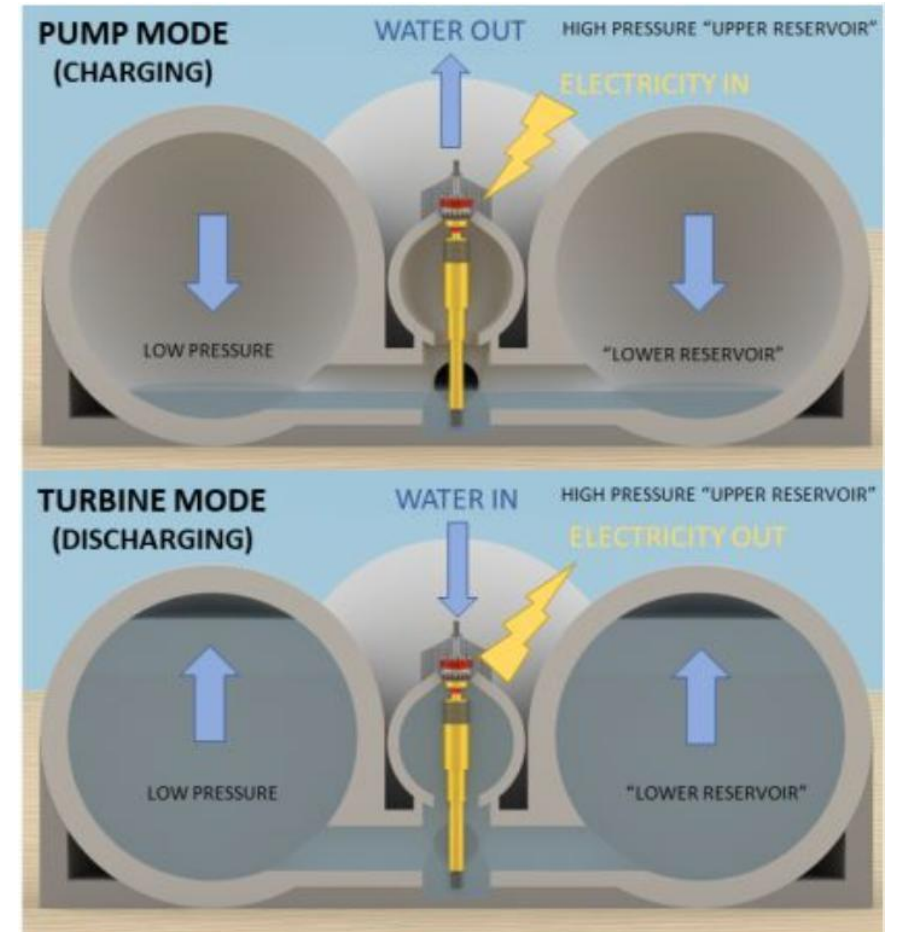

Nominally, three 30-m diameter spheres installed in 700-m water and a 5-MW pump/turbine module has a storage capacity of 60 MWh (12 hours). Increasing the spheres to 8 per pump/turbine provides 32 hours or 160 MWh of energy storage.

Targeting offshore generation to place storage close to generation. Proof of concept stage. NYSERDA funded some of this R&D

Summary



There are several different types of energy storage technologies:

- For **short duration** storage <6 hrs. **Li-ion batteries** are the **dominant** technology because of its cost competitiveness, technology readiness and commercial availability.
 - For Grid scale storage, the industry is moving towards LFP chemistry because of safety consideration.
 - Safety codes and regulations are in place to ensure battery quality and safety. NFPA 855 (installation), UL 9540 (system certification), and UL 9540A (fire testing).
 - Indoor installations are being discouraged, and the storage is moving outdoors into modular containers spaced a fixed distance apart to avoid large scale fire spreading and thermal runaway concerns.
- **Na ion batteries are emerging technology**, and they may be competitive with Li ion batteries in few years.
- **Pumped Hydro Storage** is currently the **largest grid scale energy storage**. Li ion battery storage is quickly catching up to it.
- For **longer duration storage, there are several different options** such as flow batteries, Zn halide, metal-air, compressed CO₂, compressed air, and thermal storage that may be competitive with Li ion batteries. **Several of these technologies are in the early commercialization stage.**



Planning & Zoning Considerations for Energy Storage

Energy Storage in NYS:

- Context
- Energy Storage Technologies
- **Planning & Zoning Considerations**
- Energy Storage & Fire Safety
- Resources for Local Governments
- Q&A

Each of your communities already has robust, enforceable regulations in place to ensure safety of BESS installations:

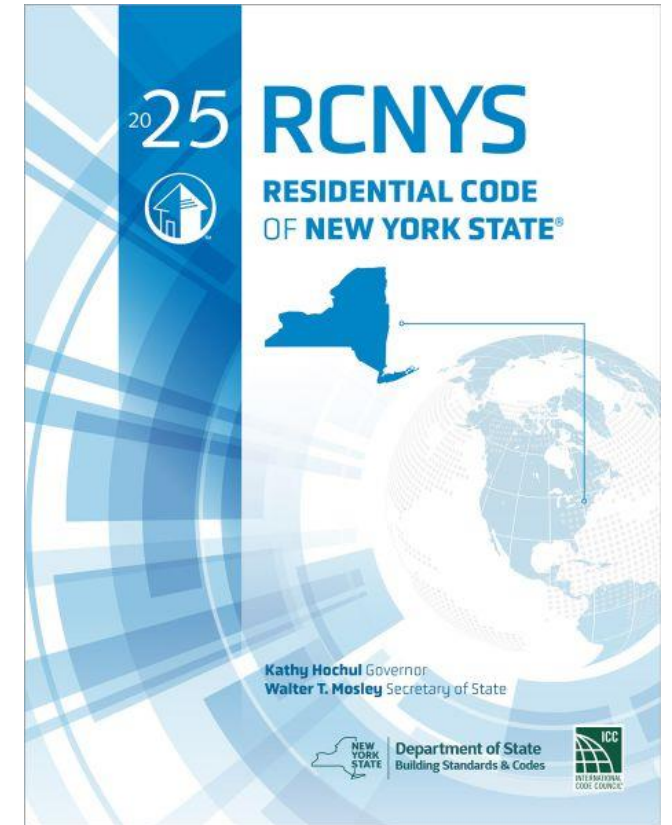
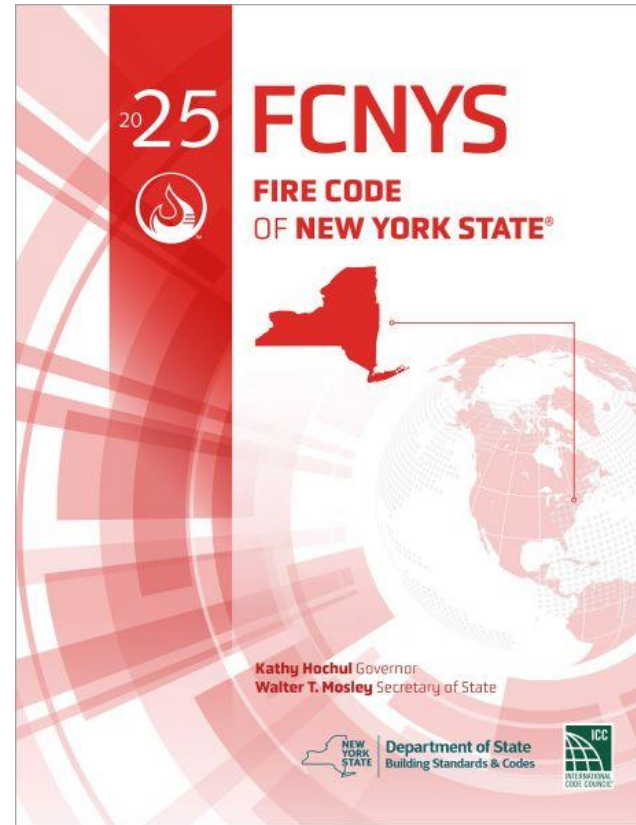

More on that to come!

Energy Storage in NYS:

- Context
- Energy Storage Technologies
- **Planning & Zoning Considerations**
- Energy Storage & Fire Safety
- Resources for Local Governments
- Q&A

Why should local governments proactively consider / plan for energy storage?

- Variety of use cases



20 kWh, residential



White Plains, NY

940 kWh, commercial



Yorktown, NY

1.85 MWh, DER



Blasdell, NY

45.6 MWh, Bulk

Planning & Zoning Considerations

What do each of those use cases / installations have in common?

They are all subject to **local permitting authority**.

Technology Type		State Permitting* (ORES)	Local Permitting (SEQR/local regulations)
Renewable Generator (e.g. solar, wind)		≥ 25 MW*	< 25 MW
Battery Energy Storage System (BESS)	Co-located with Renewable Generator	All sizes if co-located with ≥ 25 MW renewable generator	All sizes if co-located with < 25 MW renewable generator
	Standalone System	N/A	All sizes*

**Under Public Service Law (PSL) §68, electric corporations are required to seek a Certificate of Public Convenience and Necessity (CPCN) for alternate energy production facilities – including renewables and energy storage systems – exceeding 80 MW.*

Planning & Zoning Considerations

Zoom in: Local Permitting Authority

Technology Type		Local Permitting (SEQR/local regulations)
Renewable Generator (e.g. solar, wind)		< 25 MW
BESS	Co-located w/ Renewable Generator	All sizes if co-located w/ < 25 MW renewable generator
	Standalone System	All sizes



Energy Storage in NYS:

- Context
- Energy Storage Technologies
- **Planning & Zoning Considerations**
- Energy Storage & Fire Safety
- Resources for Local Governments
- Q&A

Why should local governments proactively consider / plan for energy storage?

- Variety of use cases
- Local permitting authority
- Balancing constituent / shared benefits with impacts
- Moving *beyond* moratoria

Energy Storage in NYS:

- Context
- Energy Storage Technologies
- **Planning & Zoning Considerations**
- Energy Storage & Fire Safety
- Resources for Local Governments
- Q&A

Land Use & Planning Considerations for Clean Energy Technologies:

- Electrical infrastructure (proximity, capacity)
- Appropriate locations (zoning)
- Bulk and area standards
- Environmental impacts
- Visual impacts
- Agricultural impacts
- Decommissioning
- Taxation

Energy Storage in NYS:

- Context
- Energy Storage Technologies
- **Planning & Zoning Considerations**
- Energy Storage & Fire Safety
- Resources for Local Governments
- Q&A

Land Use & Planning Considerations for Battery Energy Storage Systems:

- Electrical infrastructure (proximity, capacity)
- Appropriate locations (zoning)
- Bulk and area standards
- Environmental impacts
- Visual impacts
- Agricultural impacts
- Decommissioning
- Taxation
- **Fire safety**
- **Incident management training**

Energy Storage in NYS:

- Context
- Energy Storage Technologies
- **Planning & Zoning Considerations**
- Energy Storage & Fire Safety
- Resources for Local Governments
- Q&A

Snapshot: Geospatial mapping!

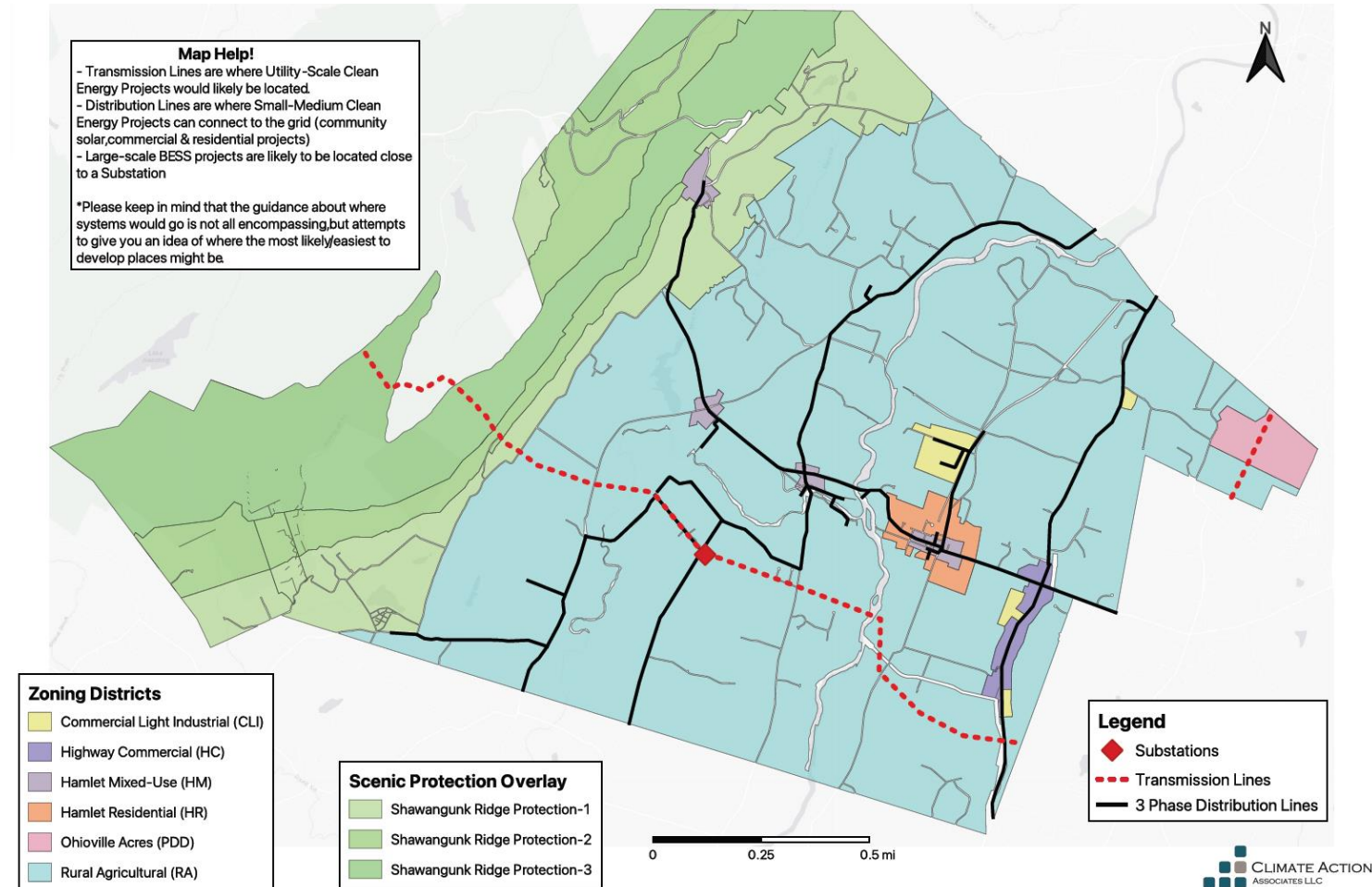

Planning & Zoning Considerations

Choosing a regulatory tool for BESS:

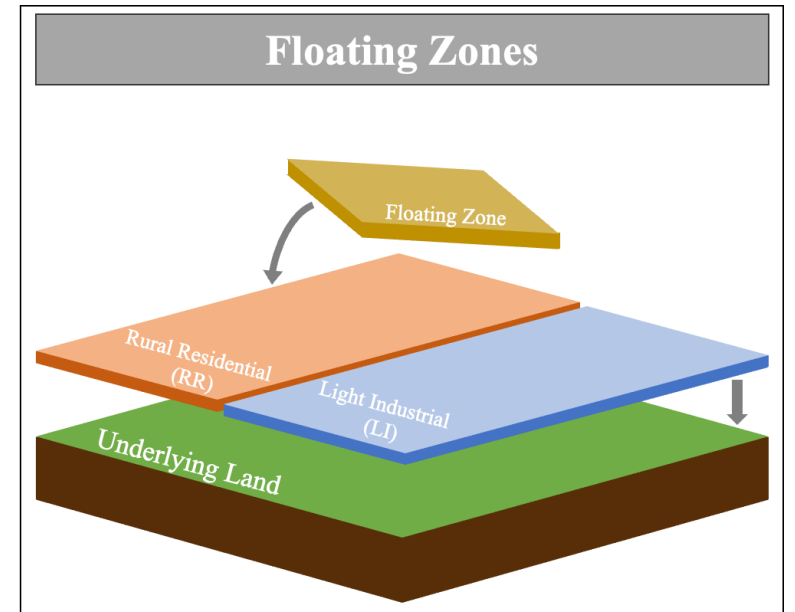
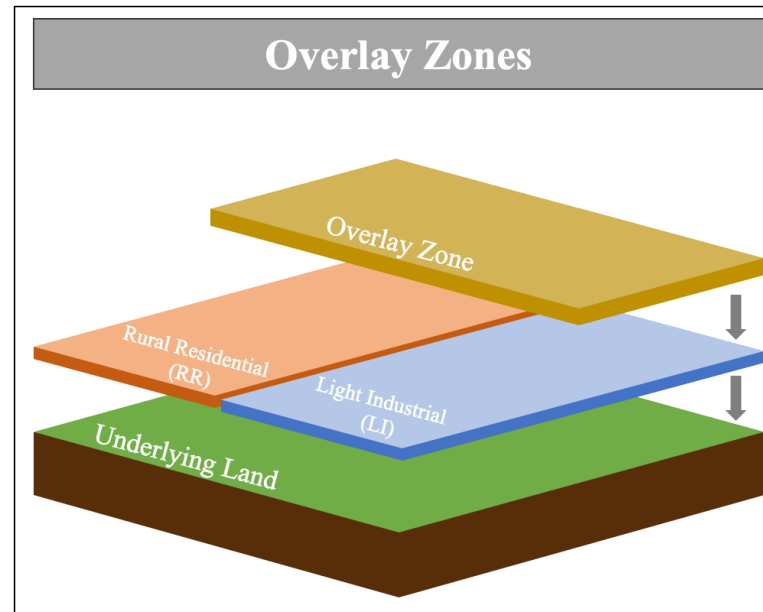
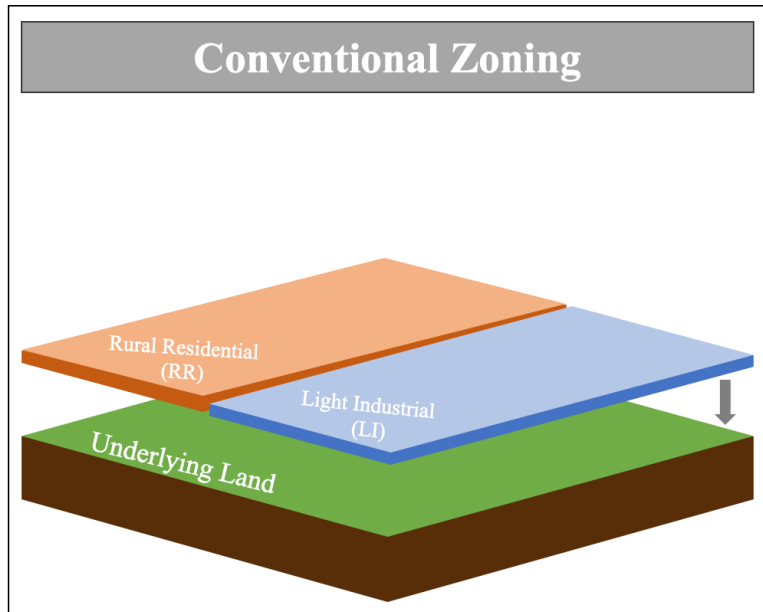

Energy Storage in NYS:

- Context
- Energy Storage Technologies
- **Planning & Zoning Considerations**
- Energy Storage & Fire Safety
- Resources for Local Governments
- Q&A

Establish Definitions to Enable Appropriate Zoning:

Tier 1

Tier 1 BESS have an aggregate energy capacity **less than or equal to 600kWh** and, if in a room or enclosed area, consist of only a single energy storage system technology.

Tier 2

Tier 2 BESS have an aggregate energy capacity **greater than 600kWh** or are comprised of more than one storage battery technology in a room or enclosed area.

Tier 1 BESS Examples

Residential BESS:



5 kW / 14 kWh installation: [Tesla Powerwall 2](#)
(5 kW / 14 kWh/unit); installed in utility space



9.8 kW / 20 kWh installation: [SonnenCore+](#),
(4.8 kW / 10 kWh/unit); installed in garage

Tier 1 into Tier 2 BESS Examples

Small to Medium Commercial BESS:



50 kW / 250 kWh installation: [Cadenza Innovation system](#), in collaboration with NYPA and NYSERDA; sited at commercial office location in White Plains, NY.



375 kW / 940 kWh installation: [Peak Power project](#), part of a virtual power plant arrangement with Con Edison; sited at commercial office location in White Plains, NY.

Tier 2 BESS Examples

Medium to Large Commercial BESS:



Yorktown, NY

490 kW / 1,856 kWh installation: [Tesla Powerpack](#) system, co-located with rooftop community solar; BESS installed in Yorktown, NY parking lot



Brooklyn, NY

750 kW / 2,500 kWh installation: Enel X project, installed at large commercial building (sports arena) in Brooklyn, NY

Tier 2 BESS Examples

Large Commercial to Grid-Scale BESS:



Brooklyn, NY

4.8 MW / 16.4 MWh installation: Enel X's [Gateway Center project](#); sited at a commercial shopping center in Brooklyn, NY



Blasdel, NY

20 MW / 45.6 MWh installation: Key Capture Energy's [KCE NY6 project](#); Blasdel, NY, adjacent to self-storage facility, landscaping/topsoil supplier, and plant nursery.

Energy Storage in NYS:

- Context
- Energy Storage Technologies
- **Planning & Zoning Considerations**
- Energy Storage & Fire Safety
- Resources for Local Governments
- Q&A

Establish Definitions to Enable Appropriate Zoning:

RECOMMENDATIONS:

- Learn about the NYS Fire Code requirements, already in place in your community; avoid duplication/conflict.
- If exploring alternate structures/definitions, base them on well-considered, legitimate source(s)
- Consider and account for the reality of system benefits:
 - *On-site* customer-serving?
 - *Remote* customer-serving?
 - Grid-serving?

Planning & Zoning Considerations

Establish Thorough and Reasonable Permitting Requirements:

Section 6: Tier 1 Battery Energy Storage Systems

- Battery Energy Storage System Permit
- Inspection Checklist
- Applicable fire code

Section 7: Tier 2 Battery Energy Storage Systems

- Special Use Permit
- Site Plan Review
- Applicable fire code

Energy Storage in NYS:

- Context
- Energy Storage Technologies
- **Planning & Zoning Considerations**
- Energy Storage & Fire Safety
- Resources for Local Governments
- Q&A

Establish Thorough and Reasonable Permitting Requirements:

For larger systems, this includes:

- Decommissioning planning (incl. consideration of funds)
- Public hearing process
- Enforcing compliance / avoiding duplication, conflict with **existing NYS Fire Code requirements**



Energy Storage & Fire Safety

Energy Storage Safety



Erin Minear, EPRI
Dr. Stephanie Shaw, EPRI
Lakshmi Srinivasan, EPRI
Justin Raade, EPRI



Nonprofit

Chartered to serve the public benefit, with guidance from an independent advisory council.



Thought Leadership

Systematically and imaginatively looking ahead to identify issues, technology gaps, and broader needs that can be addressed by the electricity sector.



Independent

Objective, scientific research leading to progress in reliability, efficiency, affordability, health, safety, and the environment.



Scientific and Industry Expertise

Provide expertise in technical disciplines that bring answers and solutions to electricity generation, transmission, distribution, and end use.



Collaborative Value

Bring together our members and diverse scientific and technical sectors to shape and drive research and development in the electricity sector.

Global Grid-Scale Storage Deployment and Failures

Failure rate continues to decrease even as deployment accelerates

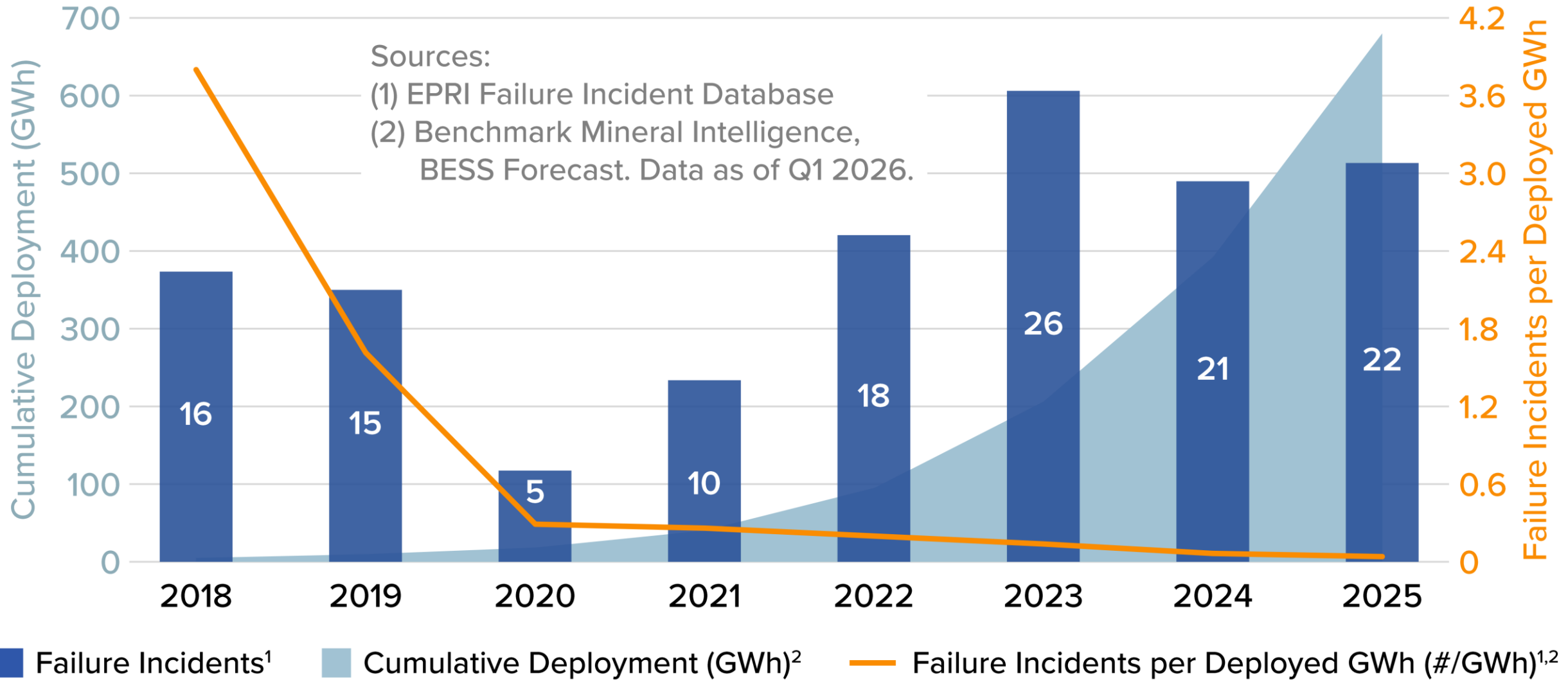

Energy Storage Fire Prevention and Mitigation

Characterize Failures
Hazard Mitigation Analysis
Design and Siting
Installation and O&M

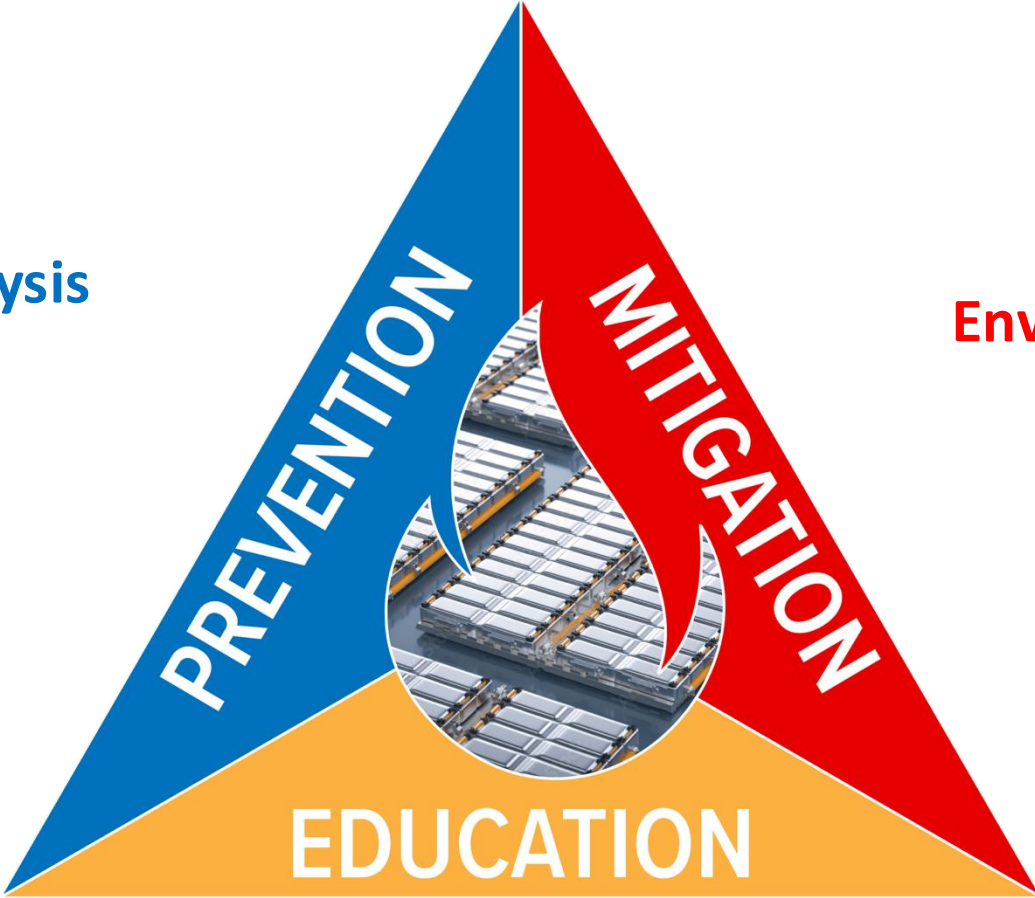

Emergency Response
Environmental Monitoring
Incident Recovery

First Responders, Permitting
Authorities, Regulators, Public

Step by Step Approach to BESS Safety

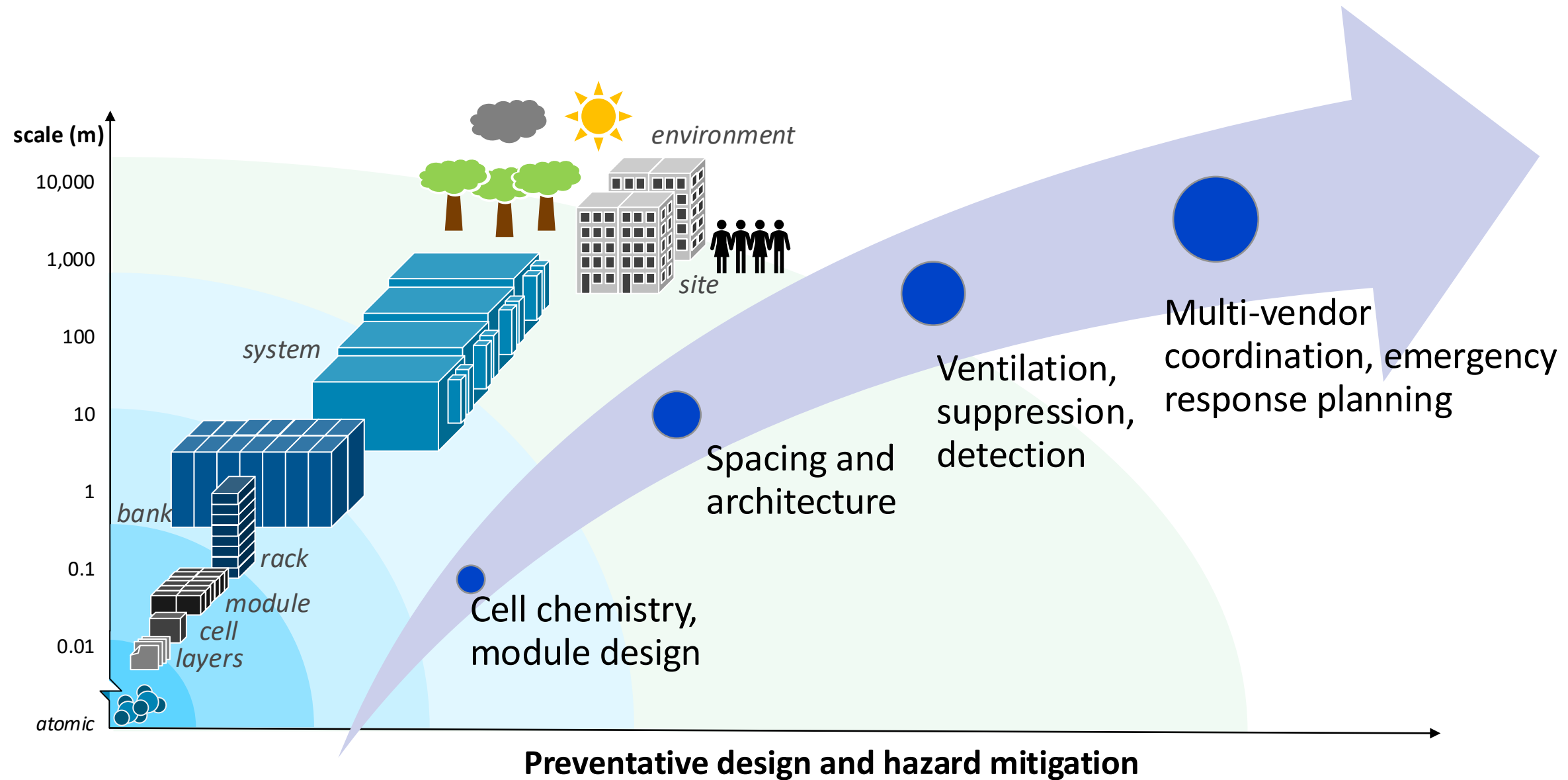

Industry Evolution

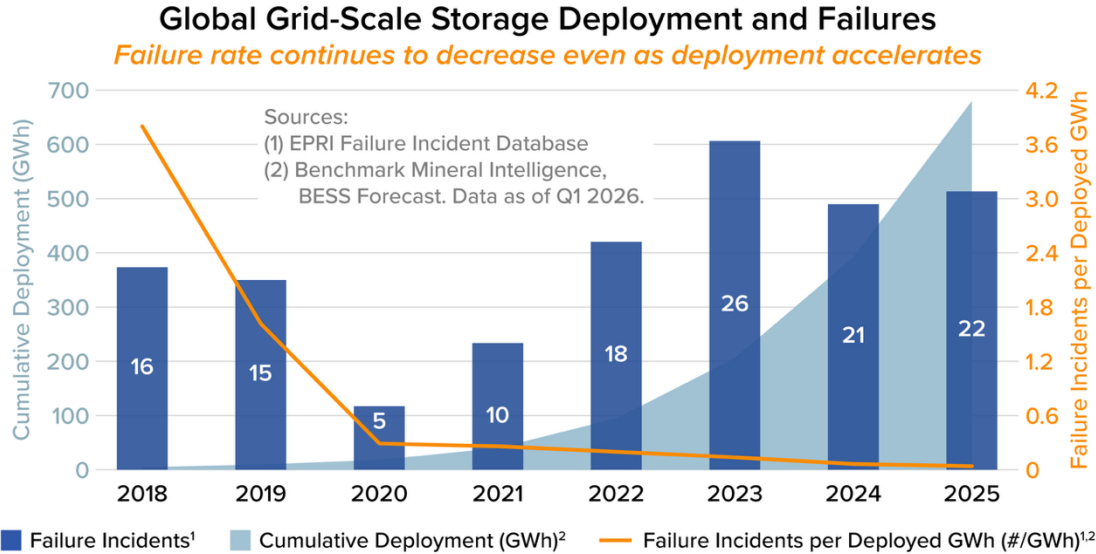

Increasing awareness and precaution in incident response

2017-19

South Korea

Multiple BESS fires and explosions

2019

Surprise, AZ

Explosion, multiple critical injuries

2022

Moss Landing, CA

Single unit fire, no injuries/fatalities, road closures, shelter-in-place

2025

Moss Landing, CA

Multiple-day fire, no injuries/fatalities, road closures, evacuation

Sources: (1) EPRI Failure Incident Database, (2) Wood Mackenzie, Global Energy Storage Outlook. Data as of 12/31/24.

Code Development Incorporated Lessons Learned

2017-19

South Korea

Multiple BESS fires and explosions

Updated released of UL 9540A
(4th edition)

2019

Surprise, AZ

Explosion, multiple critical injuries

Initial release of
NFPA 855 (2020 edition)

2022

Moss Landing, CA

Single unit fire, no injuries/fatalities,
road closures, shelter-in-place

Updated release of
NFPA 855 (2023 edition)

New and updated test methods in
UL 9540A 5th ed., CSA TS-800 1st ed.

2025

Moss Landing, CA

Multiple-day fire, no injuries/fatalities,
road closures, evacuation

Large scale fire testing required in
NFPA 855 (2026 edition) and UL
9540A (6th edition)

Injuries and Fatalities Incorporated Lessons Learned

No injuries reported in vast majority of incidents

11 incidents with known injuries or fatalities

In 6 of the 11 incidents, an explosion occurred

Firefighters accounted for 25 out of 28 injuries and fatalities. Employees accounted for 3.

Injuries and Fatalities Resulting from BESS Failures

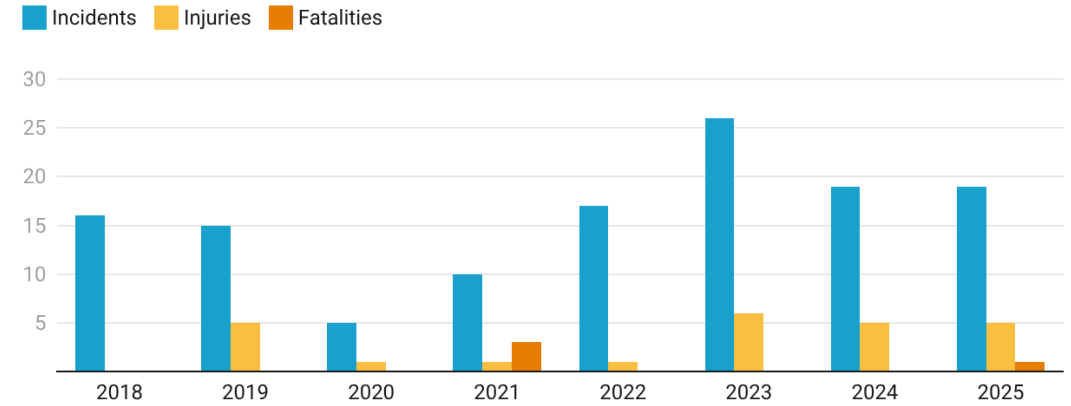

Created with Datawrapper

(1 unconfirmed fatality)

BESS Failure Incidents with Injuries and Fatalities

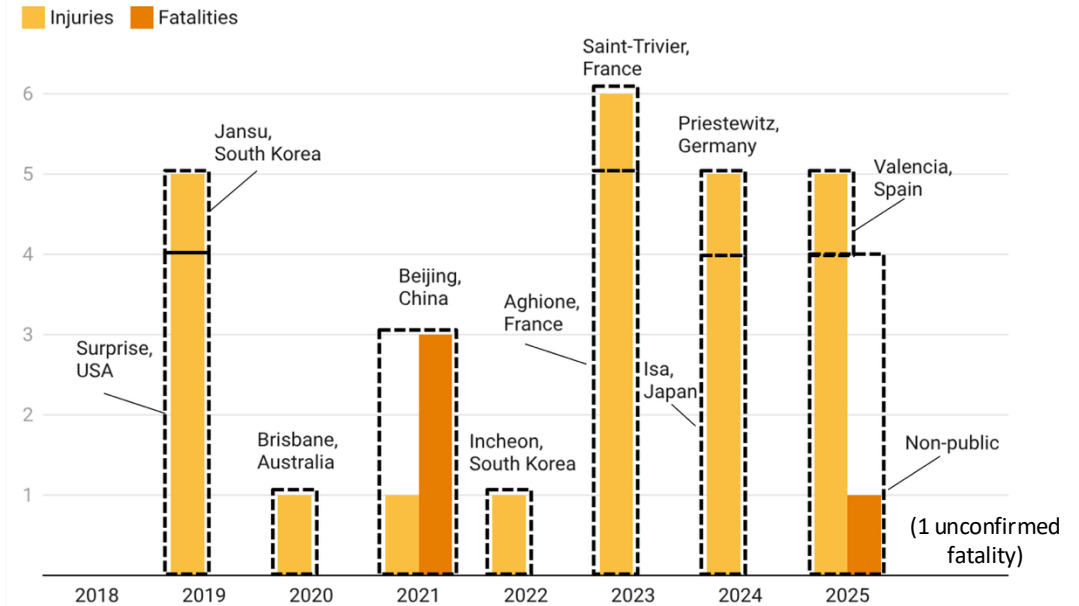

Created with Datawrapper

(1 unconfirmed fatality)

Civic Impacts

BESS incidents can result in temporary civic impacts, including:

- Road closures
- Shelter-in-place orders
- Evacuation of the surrounding community
- Less common: building evacuation, school closure, train service interruption, park closure, and damaged EV infrastructure

Evacuation and shelter-in-place decisions were often made **out of an abundance of caution**, rather than based on real-time monitoring and/or modeling

Takeaway: Identifying data driven thresholds for implementing precautionary measures is necessary to avoid causing unnecessary disruption and alarm

US BESS Failure Incidents

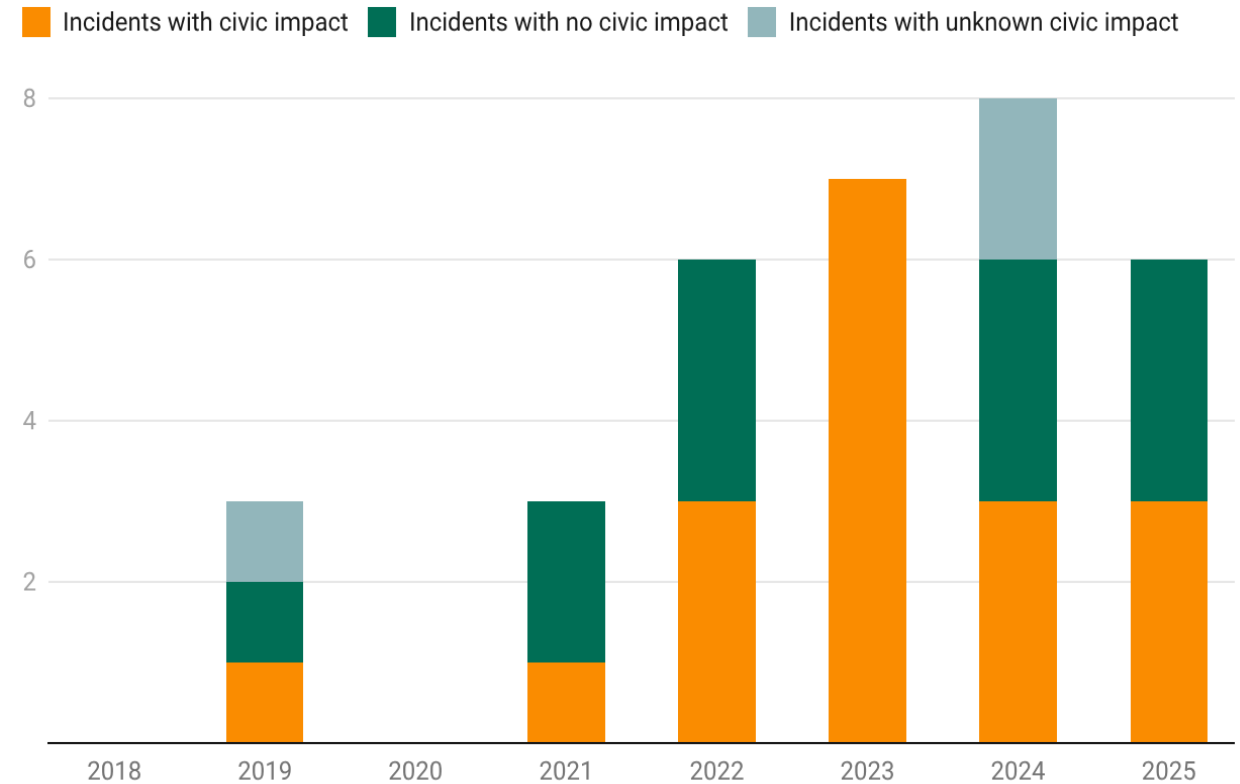

Created with Datawrapper

Energy Storage Hazards



Physical



Electrical



Arc Flash



Fire/Thermal



Pressure



Chemical









Stranded Energy



Mechanical

Lithium Ion BESS Hazards

Hazard	When Present	Description
Fire/Explosion 	Abnormal Condition	Thermal runaway, fire and explosion risk in failure condition
Electrical/Grounding 	During Normal Operation and Abnormal Condition	High voltage AC and DC
Arc flash 	During Normal Operation and Abnormal Condition	AC and DC arc flash potential
Chemical (environmental) 	Abnormal Condition	Air, water, soil pollutants in case of fire
Physical (construction/commissioning) 	Before Operation	Lifting / heavy physical objects. Commissioning – hazards present without all monitoring and safety systems online
Stranded Energy 	Always	Electrochemical energy in batteries can be released through electrical or thermal hazard

Safety Considerations for Non-Lithium Ion Emerging Technologies



Understand
hazards and
mitigation
approaches

Develop
emergency
response plans
and inform first
responders

Safety Considerations for Compressed Gas Energy Storage

Hazard	Description
Chemical	Wastewater from air compression can leach heavy metals from cavern walls and interact with lubricants, producing toxic compounds. CO ₂ systems may require leak detection due to asphyxiation risks.
Electrical	Standard electrical hazards from motor drives, control panels, and power distribution systems. Risks include arc flash, shock, and electrocution during maintenance.
Fire / Thermal	Compressed gas systems utilize thermal energy storage systems to increase efficiency, which may pose risks of burns or spills of high temperature fluids.
Mechanical	Rotating machinery (compressors, turbines, expanders) poses risks of entanglement, crushing, and pinch injuries. Maintenance protocols and shielding are essential.
Pressure	High-pressure gas storage in caverns or vessels presents risks of explosive decompression, valve failure, and seal breaches. Requires robust containment and relief systems.

Safety Considerations for Zinc-Halide BESS

Hazard	Description
Chemical	Aqueous electrolyte is non-flammable but can be corrosive or toxic if released; chemical exposure risk exists during maintenance, damage, or abnormal conditions.
Electrical	Internal shorts can occur due to non-uniform zinc plating.
Fire / Thermal	Low inherent fire risk due to non-flammable aqueous electrolyte.
Pressure	Hydrogen gas generation can occur under off-nominal electrochemical conditions; requires ventilation, detection, and pressure relief at the enclosure level.



TOGETHER...SHAPING THE FUTURE OF ENERGY®

Energy Storage & Fire Safety

NYS Inter-Agency Fire Safety Working Group

In July 2023, in response to fires in Warwick, Chaumont, and East Hampton, Governor Hochul convened the Working Group.

Agency Participants:

- Division of Homeland Security and Emergency Services (**DHSES**)
- Office of Fire Prevention and Control (**OFPC**)
- NYS Energy Research and Development Authority (**NYSERDA**)
- Department of Environmental Conservation (**DEC**)
- Department of Public Service (**DPS**)
- Department of State (**DOS**)

Working Group Partners:

- Long Island Power Authority (**LIPA**)
- New York Power Authority (**NYPA**)
- DOE-Funded National Labs
- Other highly-specialized Subject Matter Experts

Energy Storage in NYS:

- Context
- Energy Storage Technologies
- Planning & Zoning Considerations
- **Energy Storage & Fire Safety**
- Resources for Local Governments
- Q&A

NYS Inter-Agency Fire Safety Working Group

Working Group tasks include:

- **Analysis:** Oversee collection, assessment of environmental testing data, emergency response actions, Root Cause Analyses
 - **Result:** Publication of findings: no identified injuries, no harmful levels of toxins
- **Regulations:** Review existing codes, standards, and regulations; develop recommendations for revisions and enhancements
 - **Result:** Recommendations Report, updated NYS Fire Code
- **Inspections:** Conduct field inspections of in-service BESS fleet.
 - **Result:** Enhanced safety inspection protocols, checklists

Energy Storage in NYS:

- Context
- Energy Storage Technologies
- Planning & Zoning Considerations
- **Energy Storage & Fire Safety**
- Resources for Local Governments
- Q&A

Energy Storage in the NYS Uniform Fire Prevention and Building Code (Uniform Code):

- **May 2020:** 2020 Uniform Code cycle goes into effect; codifies requirements for BESS in multiple codes.
- **July 2025:** NYS Code Council adopts the 2025 Uniform Code, codifying recommendations from the Fire Safety Working Group.

The 2024 IFC is the basis of the 2025 Fire Code of New York State, which is in full effect circa Jan 1, 2026.

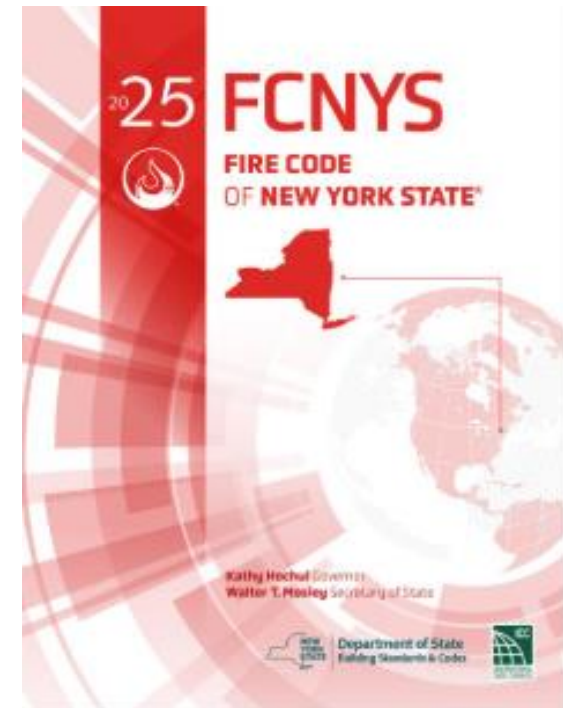

Energy Storage in NYS:

- Context
- Energy Storage Technologies
- Planning & Zoning Considerations
- **Energy Storage & Fire Safety**
- Resources for Local Governments
- Q&A

Energy Storage in the NYS Uniform Fire Prevention and Building Code (Uniform Code):

Key takeaways:

- Requires **applicant-funded peer reviews**, to ensure subject matter expert support for local officials
- Requires project-specific **Emergency Response Plans**, to be developed in conjunction with local fire department
- Requires project owners to **provide annual on-site trainings, Plan reviews**
- Requires project owner to furnish **Hazard Support Personnel** to support and collaborate with local first responders

Energy Storage in NYS:

- Context
- Energy Storage Technologies
- Planning & Zoning Considerations
- **Energy Storage & Fire Safety**
- Resources for Local Governments
- Q&A

2025 NYS Fire Code Requirements:

- Building Permits and Operating Permits required
- Permit application requirements to include, among other items:
 - Commissioning Plan
 - Decommissioning Plan
 - Fire Safety & Evacuation Plan
 - Peer Reviewer
- Hazard Mitigation Analysis
- Large-Scale Fire Testing

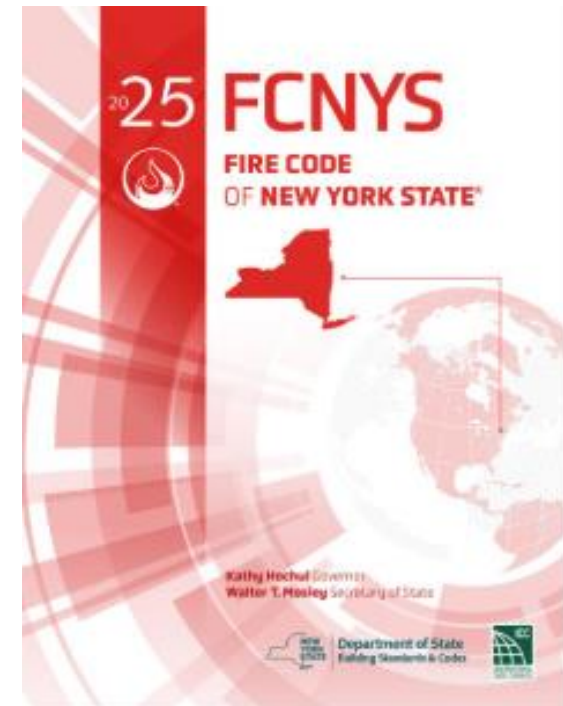

Energy Storage in NYS:

- Context
- Energy Storage Technologies
- Planning & Zoning Considerations
- **Energy Storage & Fire Safety**
- Resources for Local Governments
- Q&A

2025 NYS Fire Code Requirements:

- Hazard Mitigation Analysis (analyzes failure modes and effects)
- Large-Scale Fire Testing
- Fire Remediation:
 - Hazard support personnel
 - “...at their own expense...”
- Peer Review
- Annual Site Visit and Trainings
- 3rd Party Safety Inspections

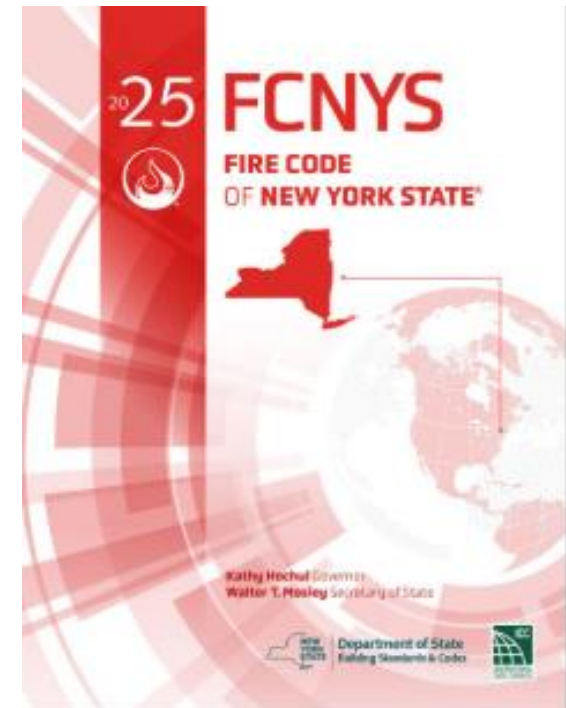

NYSERDA PEER REVIEW LAUNCH

THE PROBLEM WE FACED

Local AHJs need better support to properly review energy storage projects

WHAT WE ARE DOING ABOUT IT

Peer reviews are thorough design reviews to ensure code compliance and they are now a **requirement for all NYSERDA-funded projects**

- Three nationally renowned expert firms are contracted to conduct peer reviews on behalf of NYSERDA.
 - **Camelot Energy Group** – Seasoned renewable industry engineering professionals with deep energy storage experience
 - **DNV** – Energy storage fire safety experts who perform peer reviews on behalf of NYC Dept. of Buildings and others
 - **ESRG** – Energy storage fire safety experts consisting of former first responders and engineers

PROCESS AND RESULT

- Peer reviewers looking for compliance with FCNYS, NEC, and other applicable standards.
- Peer reviewers will work on project plans with applicant until approved and then produce a report and approval letter for applicant to pass on to the local government.



Resources for Local Governments

An aerial photograph of a utility site. In the foreground, several large, white, rectangular power transformers are arranged in rows on a gravel surface. Some transformers have metal cages around them. A white pickup truck and a white van are parked near the transformers. Several workers in high-visibility vests are visible around the site. In the background, there is a chain-link fence and a residential neighborhood with houses and trees.

Energy Storage in NYS:

- Context
- Energy Storage Technologies
- Planning & Zoning Considerations
- Energy Storage & Fire Safety
- **Resources for Local Governments**
- Q&A

NYSERDA Clean Energy Siting Team:

- **Clean Energy Guidebooks** incl. [BESS Guidebook](#)
- Hands-on **education & training opportunities**
- **Technical assistance, incl. local laws review/drafting support**
- **Pre-recorded trainings** (e.g. '[Deploying Safe Lithium-Ion Energy Storage in Your Community](#)' webinar)
- Support from regional **Clean Energy Advisors**, technical contractor resources

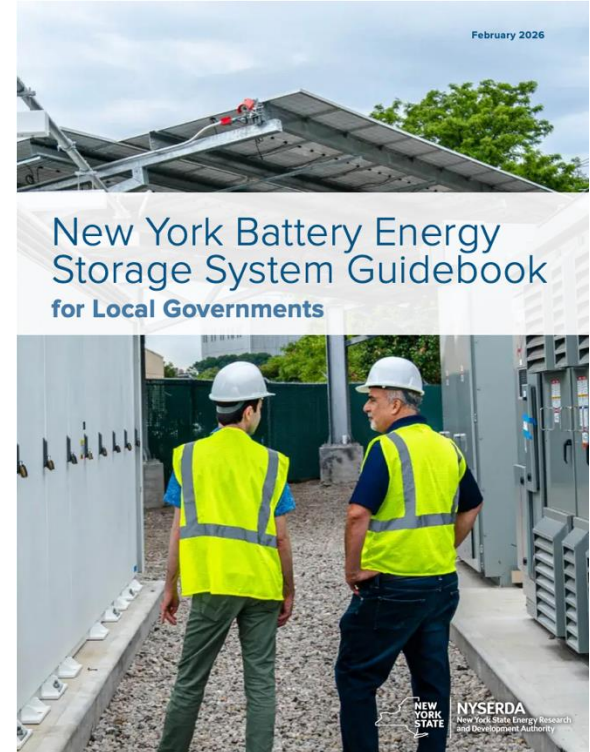

Energy Storage in NYS:

- Context
- Energy Storage Technologies
- Planning & Zoning Considerations
- Energy Storage & Fire Safety
- **Resources for Local Governments**
- Q&A

NYSERDA Clean Energy Siting Team:

NYS Inter-Agency Fire Safety Working Group:

- [Inter-Agency Fire Safety Working Group Site](#) (created December 2023)
- [Data Collection Press Release](#) (December 2023)
- [Code Recommendations Document](#) (July 2024)

NYS State Fire Prevention and Building Code Council:

- [New York 2025 Code Books](#)

Office of Fire Prevention & Control (OFPC):

- [BESS Fire Service Response Guide](#)
- [Lithium-ion Battery Awareness Course](#) (DHSES Learning Management)

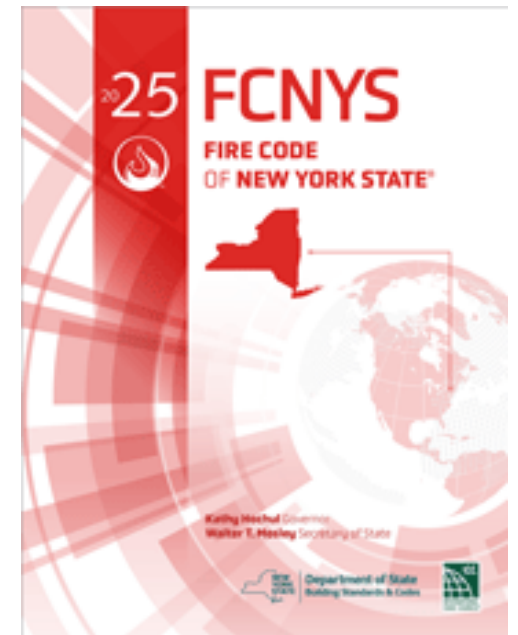

Q&A

